



Contents:

- **Lounge Seating** Page 1 - 20
- **Sofas, Chairs and Benches** Page 21 - 64
- **Restaurant Seating and Booths** Page 65 - 108
- **Restaurant Chairs and Bar Stools** Page 109 - 144
- **Tables: Restaurant, Communal and Lounge** Page 145 - 179
- **Outdoor Furniture** Page 180 - 188
- **Public Spaces Furniture** Page 189 - 194
- **Bowling Furniture** Page 195 - 197
- **Golf Furniture** Page 198 - 205



SKU: HF9Z904



PRODUCT SPECIFICATIONS

Diverse and purposeful in nature, Our HF9Z904 collection offers a sense of privacy in open spaces, fulfills standard of VIP lounge seating requirements, and when combined with Hookah tables, becomes a Modular Seating of form and function.

Built to be sturdy, pieces can be transported with ease and used in high traffic areas. Upholstered banquette seating with deep soft cushioned padding for the most comfort and support. Frame is made from solid wood. Cushions are made of high density CAL 117 certified foam. Super high-performance commercial grade vinyl featuring 500,000 double rubs, California and Boston fire codes certifications. Common applications in hospitality, healthcare, contract, education, marine and automotive industries.

Length 67.5" x 93" x 67.5"
Depth 25.5"
Height 31"
Seating Depth 21"
Seating Height 18"





SKU: HF0Z905



PRODUCT SPECIFICATIONS

Built to be sturdy, pieces can be transported with ease and used in high traffic areas. Upholstered banquette seating with deep soft cushioned padding for the most comfort and support. Frame is made from solid wood. Cushions are made of high density CAL 117 certified foam. Super high-performance commercial grade vinyl featuring 500,000 double rubs, California and Boston fire codes certifications. Common applications in hospitality, healthcare, contract, education, marine and automotive industries.

- Ushape Length 88.5" x 114"
- Depth 25.5"
- Height 52"
- Seating Depth 21"
- Seating Height 18"
- Weight Capacity per seat: 400 pounds

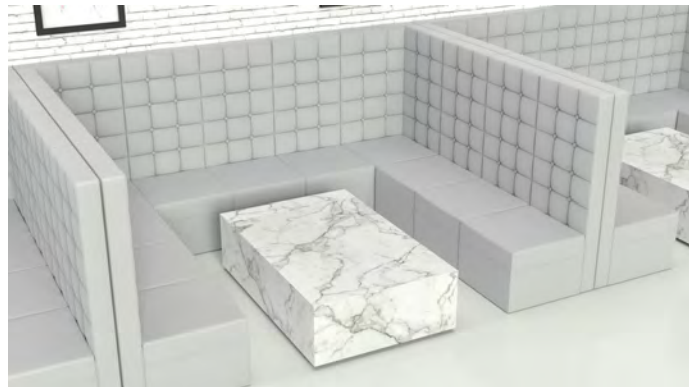



SKU: HOUSTON



PRODUCT SPECIFICATIONS

An open space area winner of the year, the HOUSTON Modular Seating can fill a room like no other. Modern Armless lounge chairs are connected with matching corners that mirror its angled qualities to create a uniquely uniform and elegant relationship that withstands scale, shape or function. From straight-line tandem seating to semi-circular and S-shaped configurations, each component is specified individually, along with a host of accessories, for creating the ideal setting.

Built to be sturdy, pieces can be transported with ease and used in high traffic areas.

Upholstered banquette seating with deep soft cushioned padding for the most comfort and support

Frame is made from solid wood. Cushions are made of high density CAL 117 certified foam. Super high-performance commercial grade vinyl featuring 500,000 double rubs, California and Boston fire codes certifications. Common applications in hospitality, healthcare, contract, education, marine and automotive industries.

Armless Chair (Extension): Length 27" | Width 29" | Height 31" |

Ottoman: Length 29" | Width 29" | Height 17.5"

Seating Depth 20.5" | Seating Height 17.5"

Overall Dimensions: Length 139" | Width 58"





SKU: PACIFIC CONVERSATION



PRODUCT SPECIFICATIONS

Elevate your establishment's ambiance with the PACIFIC CONVERSATION Lounge Seating, featuring a sleek modern design and exquisite diamond-tufted upholstery. The modular sofa's clean lines and rounded arms add a touch of sophistication, making it an ideal choice for Lounge Seating is perfect for high-end clubs, lounges, and cocktail bars, creating a contemporary and exclusive atmosphere. Its modular design makes it suitable for event spaces and banquets, allowing flexible arrangements for different layouts. It's also an excellent addition to luxury hotel lobbies, wait-ing areas, and VIP rooms, enhancing the sophistication and comfort of these spaces. .Designed for versatility, the modular pieces allow for seamless rearrangement to suit any space or occasion, providing both functionality and style.

Built to be sturdy, pieces can be transported with ease and used in high traffic areas.

Upholstered banquette seating with deep soft cushioned padding for the most comfort and support

Frame is made from solid wood. Cushions are made of high density CAL 117 certified foam. Super high-performance commercial grade vinyl featuring 500,000 double rubs, California and Boston fire codes certifications. Common applications in hospitality, healthcare, contract, education, marine and automotive industries.

Corner: Length 29" | Width 29" | Height 31" | Seating Depth 20.5" | Seating Height 17.5"

Armless Chair (Extension): Length 27" | Width 29" | Height 31" | Seating Depth 20.5" | Seating Height 17.5"

Overall Dimensions: Length 110" x Width 139"





SKU: ZEN SEATING



PRODUCT SPECIFICATIONS

Unique and Versatile in every way imaginable, the ZEN Seating Collection embodies creative freedom in the realm of commercial public seating arrangement. Arm and armless lounge seating, tables and benches align together to form configurations of curvilinear descent, classic straight-line arrangements, or a combination of both to create inspired arrangements of limitless potential.

Built to be sturdy, pieces can be transported with ease and used in high traffic areas. Upholstered banquette seating with deep soft cushioned padding for the most comfort and support. Frame is made from solid wood. Cushions are made of high density CAL 117 certified foam. Super high-performance commercial grade vinyl featuring 500,000 double rubs, California and Boston fire codes certifications. Common applications in hospitality, healthcare, contract, education, marine and automotive industries.

Armless Chair Component: Length 29" | Width 30.5" | Height 30.5"
 Seating Depth 21" | Seating Height 17.5"
 Inside Wedge Coffee Table: Length 26" | Width 13" | Height 18.5"
 Universal Arm Component: Length 28.5" | Width 3.5"
 Overall Length: 182" by 57"

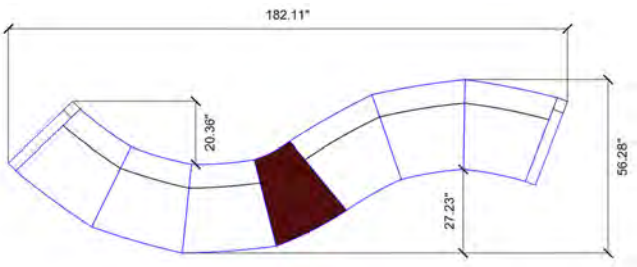



SKU: OCEAN AIR



PRODUCT SPECIFICATIONS

Introducing the OCEAN AIR Double Sided Curved Restaurant Seating Booth, the ultimate solution for optimizing space without compromising comfort or style. Crafted with innovation in mind, this meticulously designed booth features round radius seating on both sides, offering a contemporary twist to traditional restaurant seating arrangements.

With its clever layout, this booth maximizes square footage, making it an ideal choice for restaurants, hotels, and various commercial spaces where efficient space utilization is paramount. The rounded seating not only enhances the aesthetic appeal but also fosters a cozy and intimate dining experience for patrons.

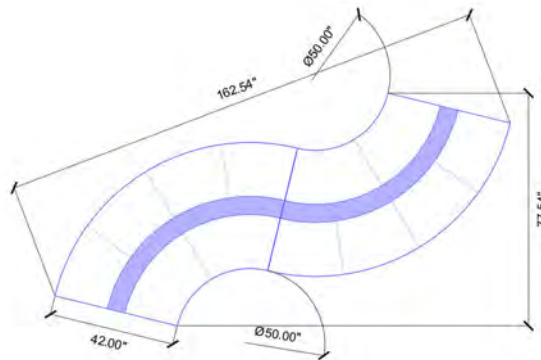

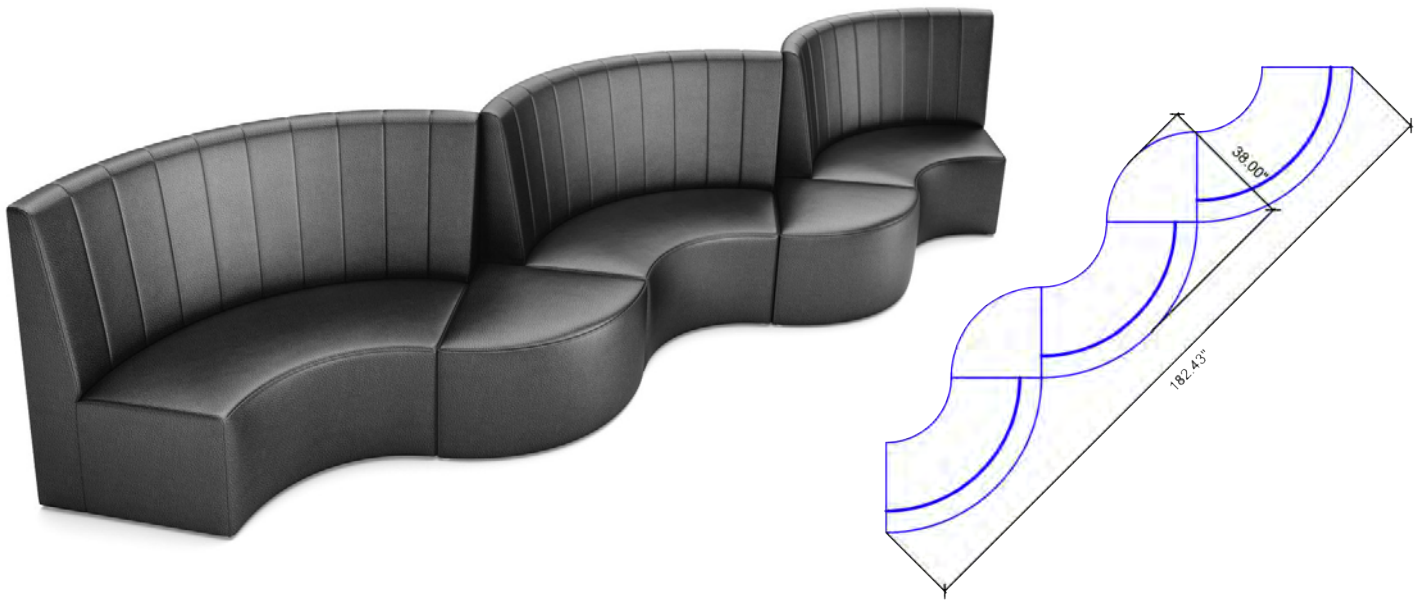

SKU: SAN DIEGO



PRODUCT SPECIFICATIONS

SAN DIEGO Modular Seating – Tailored for Restaurants, Hotels, and VIP Spaces The SAN DIEGO Collection is a sophisticated take on modular furniture, engineered for flexibility and visual impact. With a sleek 38” back height and modern vertical channel stitching, it brings elevated design to every setting — from restaurant banquettes and hotel lobby seating to upscale lounges and VIP modular seating areas. Built around three essential modules — Armless Chair, Extension Unit, and Corner Section — SAN DIEGO allows designers and facility managers to create limitless configurations.

Whether you’re designing straight rows, U-shaped layouts, L-shaped banquettes, or free-flowing lounge zones, this collection adapts effortlessly to your space. Each unit connects seamlessly, creating clean lines and maximizing seating capacity without compromising comfort. Made in the USA and built to last, SAN DIEGO is ideal for high-traffic hospitality settings that demand both style and strength. Whether you’re outfitting a boutique hotel, restaurant, nightclub, or event venue, Fortuna is the answer to dynamic, modern modular seating that works as hard as you do.





SKU: HALF CIRCLE HORIZON



PRODUCT SPECIFICATIONS

The Half-Circle Horizon Booth is a bold and inviting modular seating solution designed for upscale hospitality environments. Created by pairing two curved quarter-circle units, this arrangement forms a smooth, enclosed radius that comfortably wraps around a 36” round table —perfect for group dining, private conversations, or VIP lounge seating. The horizontal channel-tufted backrest adds a clean, modern look while delivering ergonomic comfort. This layout is especially popular in restaurant banquettes, hotel lobbies, and social club lounges looking to elevate both form and function. Built in the USA with commercial-grade materials, the Half-Circle Horizon Booth is durable, stylish, and ready to make a lasting impression.

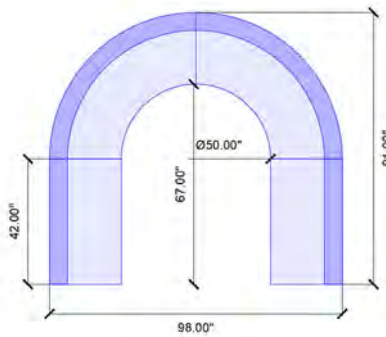



SKU: HFX TRENTON



PRODUCT SPECIFICATIONS

This HFX TRENTON is a versatile commercial lounge seating collection composed of multiple Modular Sofa sections that can be arranged in various Soft Seating configurations. It typically includes Lounge seating components, allowing for customizable layouts to suit different area sizes and preferences, which is well tailored for superb comfort. HFX TRENTON collection provides perfect contemporary seating solutions for public spaces in your high traffic environment. Our HFX TRENTON Collection Design beautifully corresponds where the gunmetal metal fully welded frame is connected to upholstered seats and backs making it a great composition of styles and finishes.

Built to be sturdy, pieces can be transported with ease and used in high traffic areas.

Upholstered banquette seating with deep soft cushioned padding for the most comfort and support

Frame is made from solid wood. Cushions are made of high density CAL 117 certified foam. Super high-performance commercial grade vinyl featuring 500,000 double rubs, California and Boston fire codes certifications. Common applications in hospitality, healthcare, contract, education, marine and automotive industries.

Length: 75" x 102" x 75"

Depth: 27"

Height: 28"

Seating Height 18"

Seating Depth: 24"

Back Thickness: 6"





SKU: HFZ TRENTON



PRODUCT SPECIFICATIONS

The HFZ TRENTON Modular Seating collection redefines modern luxury with its sleek lines and contemporary style. Designed with versatility in mind, this collection features modular components, including unique radius corners, allowing for endless layout possibilities to suit any space. Each piece is expertly tailored for exceptional comfort, combining ergonomic design with high-quality materials that endure the demands of high-traffic public areas.

HFZ TRENTON's modular design makes it the perfect solution for clubs, lounges, and other social venues, offering both flexibility and elegance. The collection's durable construction and premium upholstery ensure long-lasting performance, while its sophisticated aesthetic enhances the ambiance of any modern environment. Whether creating intimate seating arrangements or expansive sectional layouts, HFZ TRENTON delivers a seamless blend of style and functionality.

Width: 75" x 102" x 75"
Depth: 27"
Height: 28" or 42"
Seating Height 17.5"
Seating Depth: 21"
Each Arm: 6"





SKU: HFX CHARLOTTE



PRODUCT SPECIFICATIONS

Built to be sturdy, pieces can be transported with ease and used in high traffic areas. Upholstered banquette seating with deep soft cushioned padding for the most comfort and support. Frame is made from solid wood. Cushions are made of high density CAL 117 certified foam. Super high-performance commercial grade vinyl featuring 500,000 double rubs, California and Boston fire codes certifications. Common applications in hospitality, healthcare, contract, education, marine and automotive industries.

Gunmetal powder coated carbon steel frame is fully welded - built to be used in high traffic areas.

Extension Component:	Corner Component:
Length: 48"	Length: 27"
Depth: 27"	Depth: 27"
Height: 32"	Height: 32"
Seating Depth: 20"	Seating Depth: 20"
Seating Height: 18"	Seating Height: 18"





SKU: HFZ CHARLOTTE



PRODUCT SPECIFICATIONS

HFZ CHARLOTTE is a modular lounge seating with luxurious comfort and feel - built to be used in high traffic areas.

Built to be sturdy, pieces can be transported with ease and used in high traffic areas.

Upholstered banquette seating with deep soft cushioned padding for the most comfort and support

Frame is made from solid wood. Cushions are made of high density CAL 117 certified foam. Super high-performance commercial grade vinyl featuring 500,000 double rubs, California and Boston fire codes certifications. Common applications in hospitality, healthcare, contract.

Ushape Length: 73" x 102" x 73"

Depth: 27"

Height: 32"

Seating Depth: 20"

Seating Height: 17"

Each Arm: 3"





SKU: HF HIDEAWAY



PRODUCT SPECIFICATIONS

The HF HIDEAWAY collection responds to the realities of lounging and socializing of everyday use in high traffic areas, a perfect addition to any Hospitality or Lounge Furniture Seating space. Versatile, beautiful, luxurious and modular furniture components - fits nicely in most spaces. This Button Tufted style collection is unique and it can work with many different interiors such as rustic, modern, retro, industrial or vintage. If you are planning to change the Modular Configuration according to the amount of your guest you will easily be able to accomplish that by moving and reconnecting the units. Get creative and make a statement with this “Chesterfield” style collection to attract your clients

Overall Length: 92.5” x 92.5”
Overall Width: 29”
Overall Height: 31”
Seating Depth 20.5”
Seating Height 17.5”





SKU: HFS STYLE



PRODUCT SPECIFICATIONS

The HFS STYLE makes a bold statement with its elegant curve and understated flat back design. HFS STYLE is ideal for restaurant banquettes, hospital-ity lounges, or private dining spaces. Its solid wood base anchors the form while the clean, upholstered surfaces offer comfort and durability. Built in the USA, this modular furniture piece invites conversation and enhances ambiance with its tailored shape and premium presence. A must-have layout for venues seeking intimacy with style.

Overall outside perimeter as pictured: 86" by 106" by 86"
 Extension with Left or Right Curved Seat: L 44" | D 25"
 Short Extension: L 22" | D 25" | H 36"
 Corner: L 42" | D 42" | H 36"
 Seating Depth 19"
 Seat Height 18.5"

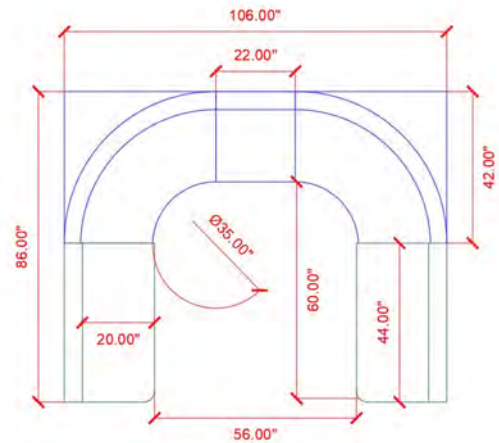



SKU: ATLANTIC U-BOOTH



PRODUCT SPECIFICATIONS

The ATLANTIC U-BOOTH seating features a clean, straight backrest that delivers a traditional, no-nonsense aesthetic — ideal for diners, cafés, or casual restaurant settings. Its simple silhouette maximizes seating space and allows for tight wall placement, making it a go-to for efficiency without sacrificing style. The flat back offers a timeless look that blends easily into any interior concept. Built with 4” black legs and a weight capacity of 350 lbs. per seat, it’s made in the USA for lasting durability. This budget-friendly booth connects easily in a line, offering both practicality and understated charm. Availalbe in Flat, Channel and Diamond back.

Armless Extension Length 48” | Depth 24.5”
 Corner Length 24.5” | Depth 24.5”
 Overall Length: 72.5” x 97” x 72.5”
 Overall Height: 36” or 42”





SKU: CHARLESTON MODERN BOOTH



PRODUCT SPECIFICATIONS

Combining the comfort of a lounge chair with partitions for privacy, CHARLESTON MODERN BOOTH provides a welcome and quiet space to sit, work, eat and focus. Restaurant Seating and Partition elements can be configured together to create stand-alone Modern Booth Sections and modules, clusters of single-user spaces, or expand into multi-user settings for various meeting requirements. Built to be sturdy, pieces can be transported with ease and used in high traffic areas.

Upholstered banquette seating with deep soft cushioned padding for the most comfort and support. Frame is made from solid wood. Cushions are made of high density CAL 117 certified foam. Super high-performance commercial grade vinyl featuring 500,000 double rubs, California and Boston fire codes certifications. Common applications in hospitality, healthcare, contract.

Ushape Length: 70" x 92" x 70"
 Depth: 22"
 Height: 42"
 Seating Depth: 19"
 Seating Height: 18"

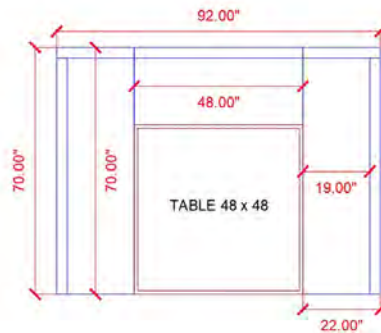



SKU: HF8500



PRODUCT SPECIFICATIONS

The HF8500 Curved Seating is the heart of the modular collection. Designed to comfortably seat three guests, this elegant piece features a soft arc that brings natural flow to any seating arrangement. Perfect for building long curved lounge areas, this modular seating component offers deep seating and plush support—ideal for hotels, lounges, and public spaces. Connect it to other HF8500 pieces for seamless, sculptural seating. Upholstered banquette seating with deep soft cushioned padding for the most comfort and support. Frame is made from solid wood. Cushions are made of high density CAL 117 certified foam. Super high-performance commercial grade vinyl featuring 500,000 double rubs, California and Boston fire codes certifications. Common applications in hospitality, healthcare, contract.

Left-Sided Chaise: Length 77" | Width 34" | Height 31"
 Extension Component: Length 70" | Width 34" | Height 31"
 Open Chaise: Length 70" | Width 34" | Height 31"
 Seating Depth 26" | Seating Height 18"

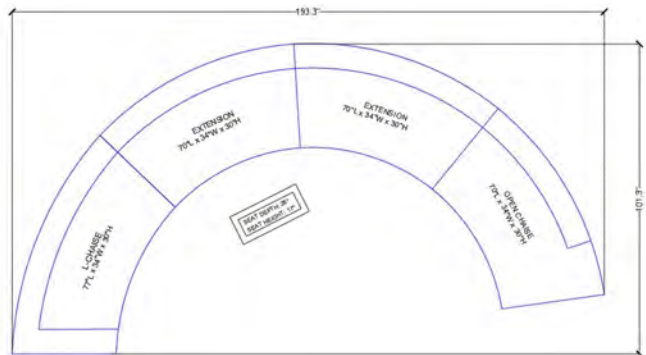



SKU: HL8600L



PRODUCT SPECIFICATIONS

This model HL8600L will give your facility an exceptional style and look of the modern lounge area. The durability, comfort and style will give your Lounge seating area many years of use in any environment. The versatility it offers, with so many custom seating options available there is no décor it can't fit into. Optimization of a space with the ideal restaurant modular seating is essential to bringing creativity to a restaurant décor as well as customer satisfaction. This modular sofa helps reduce traffic as well as create a great sense of comfort. These are some of the many reasons why it is virtually a perfect choice for any dining establishment , office lounge area and more. Can be manufactured in any color or back panel design flat or channel back.

- Length 130"
- Depth 34" (curved 49.5")
- Height 32"
- Seating Depth 26"
- Seating Height 18"
- Overall Recommended Perimeter : 130" x 150"

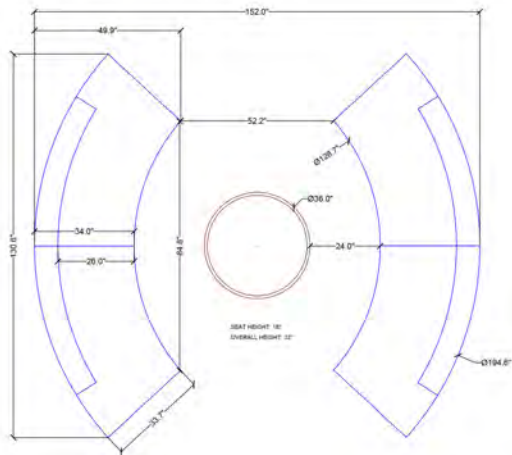
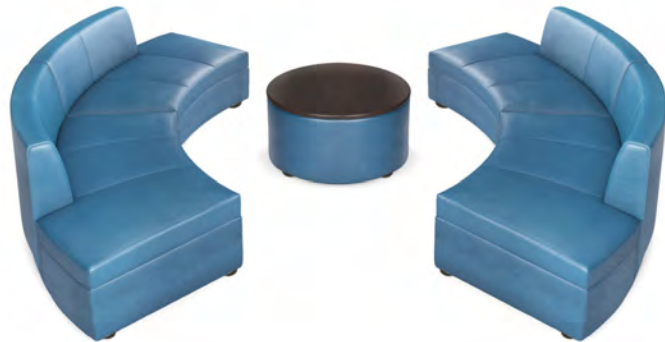



SKU: BOUGIE



PRODUCT SPECIFICATIONS

BOUGIE is a modern commercial extra wide and hefty lounge half-circle booth with a channel design which offers an elegant and functional seating option designed to enhance the dining and lounge experience. The booth features a sleek, contemporary design characterized by its clean lines and sophisticated appearance. Ideal for modern dining establishments, these booths can be customized in various colors, sizes, and finishes to complement the restaurant's décor and layout. They provide a cozy and intimate dining space for guests, making them a popular choice for both casual and upscale dining venues

- Outer Diameter: 124"
- Inner Diameter: 58"
- Depth: 32'
- Height: 35"
- Seating Depth: 24"
- Back Width: 10"
- Seating Height: 17"

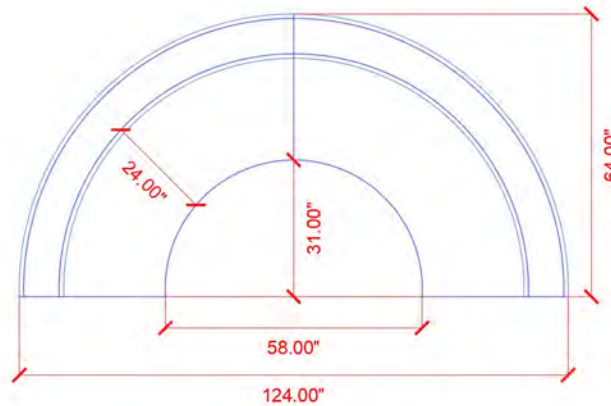



SKU: HFT500



PRODUCT SPECIFICATIONS

Uniquely crafted, with Modern mid century style and exceptional comfort as its forte, Our HFT500 Collection effortlessly finds its place in corporate lobbies, healthcare environments, hospitality lounges and more. Modular seating configurations for any open space areas will provide maximum seating potential while showing its style as a stand-alone Sofa or Chairs, that serves any number of purposes. HST005 is a modern urban modular collection, which is well tailored for superb comfort. HFT500 collection provides perfect contemporary seating solutions for public spaces in your high traffic environment.

Left / Right component:	Extension component:
Width: 47"	Width: 42"
Depth: 27"	Depth: 27"
Height: 27"	Height: 27"
Seating Height 18"	Seating Height 18"
Seating Depth: 23"	Seating Depth: 23"
Cushion Thickness: 4.75"	



Corner component:
 Width: 27"
 Depth: 27"
 Height: 27"





SKU: HFXS CHARLOTTE



PRODUCT SPECIFICATIONS

The HFXS CHARLOTTE Sofa is designed to meet the high demands of hospitality spaces, combining rugged construction with inviting comfort. Its standout feature is the full-length armrest support, ergonomically molded to cradle the body from shoulders to palms — perfect for guests who value both relaxation and style. Built in the USA, the sofa's fully welded gunmetal steel frame gives it an unmistakable industrial edge, complement-ed by a modern tweak that elevates any space. With a weight capacity of 350 lbs per seat, the HFXS CHARLOTTE Sofa is a perfect fit for commercial use in restaurants, hotels, and open lounges. Its balanced mix for any hospitality setting, creating comfortable zones that encourage connection and socializing with comfort.

Length: 48" (2-Seater), 73" (3-Seater)
Depth: 27"
Height: 32"
Seating Depth: 20"
Seating Height: 18"
Each Arm: 3"





SKU: HFX2S CHARLOTTE



PRODUCT SPECIFICATIONS

Diverse and purposeful in nature, HFX2S CHARLOTTE Modular Collection offers a sense of privacy in open spaces, fulfills standard lounge seating requirements, and when combined with connecting tables, becomes a modular oasis of form and function. Collection includes lounge chairs, left and right side chaises, straight benches and ottomans. Optional accessories as Laminate Table Tops and Charging stations.

Gunmetal carbon steel frame is fully welded - built to be used in high traffic areas.

Optional Walnut Center Table: upholstery same as sofas, powder coated carbon steel frame is fully welded - built to be used in high traffic areas. Laminate Formica® Table Top is 1.125". Stain, scratch and impact resistant under normal use conditions.

Length: 96"

Depth: 27"

Height: 32"

Seating Depth: 20"

Seating Height: 18"

Each Arm: 3"

Optional Center Table:

Square: 27"

Height: 17.5"

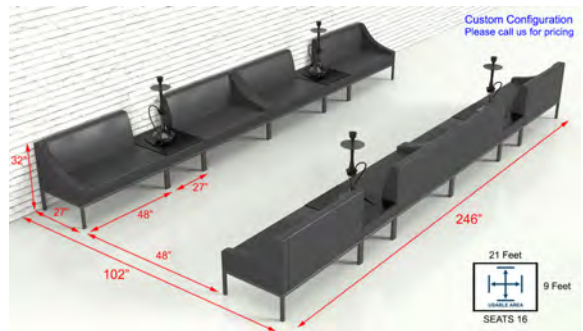



SKU: HFZS CHARLOTTE

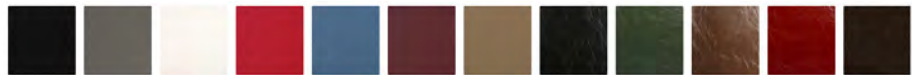

PRODUCT SPECIFICATIONS

The HFZS CHARLOTTE Sofa brings a touch of modern elegance and comfort to any commercial setting. Its signature slanted arms create a graceful “wave” from the top of the back panel to the bottom, offering full arm support for guests. Crafted in the USA with sturdy 4 inch metal legs, this sofa supports up to 350 lbs, making it ideal for hospitality lounges, public spaces, and stylish gathering areas. The HFZS CHARLOTTE Sofa’s clean lines, plush upholstery, and versatile color options make it a stunning choice for any environment that prioritizes both comfort and style.

Length: 48” (2-Seater), 73” (3-Seater)
Depth: 27”
Height: 32”
Seating Depth: 20”
Seating Height: 17”
Each Arm: 3”





SKU: HFZ96S CHARLOTTE



PRODUCT SPECIFICATIONS

HFZ96S CHARLOTTE is a modular lounge seating with luxurious comfort and feel - built to be used in high traffic areas. Upholstery options: Symphony Collection Classic: The supple hand and texture of pebble grain leather with Resilience-SR protection. Super high-performance commercial grade-vinyl featuring 500,000 double rubs. Glossy Glaze Collection: Features beautiful, smooth and semi-glossy leather grain pattern. Soft-Feel Como Fabric Upholstery. Features beautiful and soft fabric pattern. Phthalate free and Lead free. It is California TB 117 fire code certified.

Length: 96" (Left Side 48" and Right Side 48")
Depth: 27"
Height: 32"
Seating Depth: 20"
Seating Height: 17"
Each Arm: 3"





SKU: TRENTON X SOFA



PRODUCT SPECIFICATIONS

TRENTON X SOFA is a modern two-seater sofa, which is well tailored for superb comfort. Built to be both lightweight and sturdy, pieces can be trans-ported with ease and used in high traffic areas. Frame is built of solid hardwood. Cushion is made of high density CAL 117 certified foam. Joints are glued, stapled and screwed to ensure frame stability and longevity. Base sits on metal base glides
Carbon steel frame is fully welded with a powder coated gunmetal finish.

Length: 60" (2-Seater) or 73" (3-Seater)
Depth: 27"
Height: 28"
Seating Height 18"
Seating Depth: 24"
Each Arm: 6"





SKU: TRENTON Z SOFA



PRODUCT SPECIFICATIONS

Our modern sofa is the perfect addition to any hospitality environment. Combining sleek design and superior craftsmanship, it delivers both style and functionality. Whether for clubs, lounges, social venues, or other hospitality facilities, this commercial-grade furniture offers maximum seating capacity without compromising on comfort or durability. Take your hospitality space to the next level by pairing the modern sofa with our matching armchair. Together, they create a cohesive and inviting seating arrangement that blends comfort, style, and practicality

Length: 60" (2-Seater) or 73" (3-Seater)
Depth: 27"
Height: 28"
Seating Height: 17.5"
Seating Depth: 21"
Each Arm: 6"





SKU: HF VICTORY SOFA



PRODUCT SPECIFICATIONS

HF VICTORY SOFA Sofas have been voted and rated as a top choice for public seating thanks to their versatile design and premium construction. Designed for educational spaces, hospitality lounges, and collaborative work areas, the HF VICTORY SOFA collection offers more than just comfort — it's about adaptability. Each piece can be used as a standalone seating solution or enhanced with privacy panels, charging stations, and study pods, creating focused capsules for students, guests, or professionals. The sleek lines and high-quality upholstery blend modern style with commercial-grade durability, making them ideal for libraries, university study areas, hotel lobbies, and more. Built in the USA with meticulous craftsmanship, the HF VICTORY SOFA collection delivers reliable performance and a contemporary look that elevates any space. Comfort, flexibility, and function — all in one seating solution.

Length: (2-Seater) 58.5" or (3-Seater) 83.5"
Depth: 28"
Height: 28"
Seating Height 17.5"
Seating Depth: 21"





SKU: HFDOUBLE WING



PRODUCT SPECIFICATIONS

The HFDOUBLE WING Sofa and HFDOUBLE WING Sofa Package are designed to meet the demands of universities, libraries, schools, and collaborative workspaces — where comfort, style, and functionality are essential. Upholstered in premium materials with refined stitching, this sofa offers a modern aesthetic that fits seamlessly into any setting. What sets the HFDOUBLE WING apart is its built-in swivel trays and integrated power outlets, providing ultimate convenience for studying, working, or relaxing. The sturdy construction, supported by a fully welded metal frame, ensures long-lasting durability even in high-traffic environments. Perfect for open lounges, student centers, and social hubs, the HFDOUBLE WING combines ergonomic seating with smart design, enhancing both productivity and relaxation. Crafted in the USA with meticulous attention to detail, this sofa is as reliable as it is stylish — the perfect choice for any public space that demands both form and function.

Length: 69"
Depth: 28"
Height: 28"
Seating Height: 18"
Seating Depth: 21"





SKU: MIAMI SOFA



PRODUCT SPECIFICATIONS

The MIAMI Sofa combines modern luxury with classic charm, making it a favorite for hospitality environments and open lounge spaces. With its button tufting and deep cushions, this sofa brings a cozy, tailored look that never goes out of style — a true classic that fits seamlessly into contemporary settings. The metal frame construction not only provides strong support and a solid foundation but also enhances the sofa's visual appeal with sleek, modern lines. With a weight capacity of 350 lbs per seat, the MIAMA is as durable as it is elegant, handling daily use with ease. From boutique hotels to high-end restaurants and lounges, the MIAMI Sofa blends the warmth of tradition with the clean lines of modern design. This warm mixture of modern and classic style ensures that the MIAMI Sofa remains a standout in any environment.

Length: 48" (2-Seater), 73" (3-Seater)
Depth: 27"
Height: 31"
Seating Depth: 21"
Seating Height: 16.5"
Each Arm: 3"





SKU: OHIO SOFA



PRODUCT SPECIFICATIONS

The OHIO Sofa is proof that sometimes simplicity is the ultimate sophistication. Designed to deliver exceptional comfort and versatility, this sofa has become a go-to choice for hospitality spaces, restaurants, lounges, and commercial environments. Its clean lines and plush cushioning create a welcoming atmosphere that works in nearly any setting, while the solid construction ensures durability and long-lasting support. Each seat is engineered to hold up to 350 lbs, making it perfect for high-traffic areas without sacrificing style or comfort. Fully customizable in upholstery and finish, the OHIO Sofa can be tailored to blend with any interior color scheme or brand identity. Whether it's a modern hotel lobby or a cozy restaurant waiting area, the Oscar is built to meet the moment — and elevate the experience. Simple, comfortable, and a crowd-pleaser for every space.

Length 51" (2-Seater), 70" (3-Seater)
Depth 28"
Height 31"





SKU: PALM BEACH SOFA



PRODUCT SPECIFICATIONS

Uniquely crafted, with Modern mid century style and exceptional comfort as its forte, Our PALM BEACH SOFA Collection effortlessly finds its place in corporate lobbies, healthcare environments, hospitality lounges and more. Modular seating configurations for any open space areas will provide maximum seating potential while showing its style as a stand-alone Sofa or Chairs, that serves any number of purposes.

Sofa's frame is made from solid wood. Base frame is made from 1" carbon steel powder coated gunmetal finish. Cushions are made of high density CAL 117 certified foam. Joints are glued, stapled and screwed to ensure frame stability and longevity.

Length: 52" or 73"
Depth: 27"
Height: 27"
Seating Height 18"
Seating Depth: 23"
Cushion Thickness: 4.75"



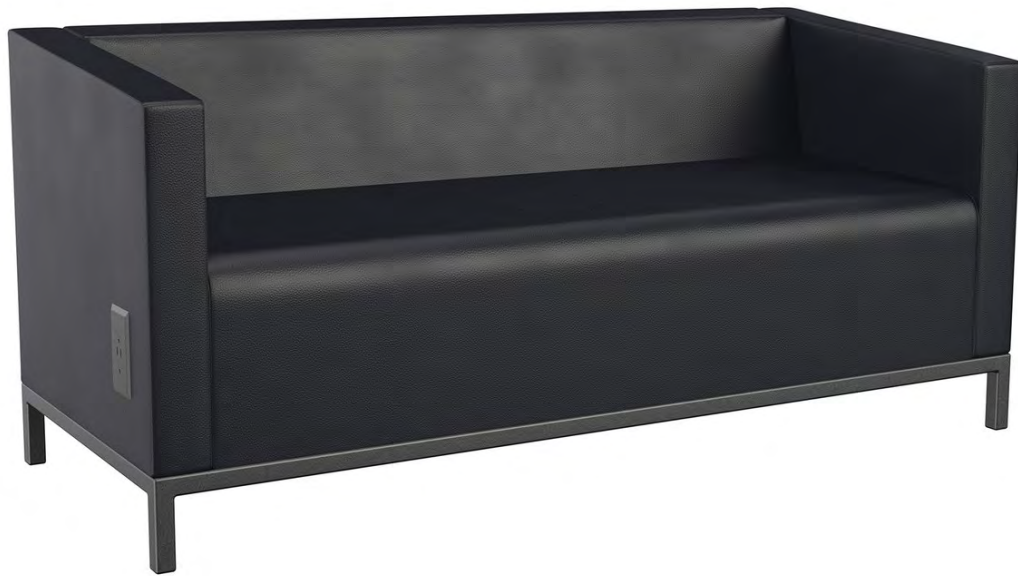

SKU: SEDONA SOFA



PRODUCT SPECIFICATIONS

Whether in lobbies or public areas, or casual meeting environments and touchdown spaces, This Modern Commercial chair abounds with possibilities. Lounge chairs with casters or Metal Frame make an excellent choice for workgroups – the ever growing collaborative work style. Rotating tablet or pull-up table and Heavy duty commercial and functional chair becomes the gateway to productive freedom. Yet for all its functionality, SEDONA SOFA is equally pleasing in traditional lounge settings where simply waiting in comfort is all that is required.

Length: 48" (2-Seater), 73" (3-Seater)
Depth: 27"
Height: 34"
Seating Depth: 21"
Seating Height: 18"
Each Arm: 3"



Upholstery (Seating):
Classic American Beauty SCL-003

Upholstery (Outline):
Standard Black



SKU: ROYALTY SOFA



PRODUCT SPECIFICATIONS

Designed for both style and functionality, our sofa seamlessly combines modern aesthetics with timeless charm. Its brass railhead outline, carefully tailored stitching, and graceful silhouette effortlessly blend into any decor scheme, making it a versatile focal point of any hospitality space. The ROYALTY SOFA collection responds to the realities of lounging and the rigors of everyday use in high traffic area, a perfect addition to any hospitality space. Brass railhead outline provides alluring sophistication. This sofa will give your establishment or event an exclusive design with commercial grade quality.

Length 57", 78"
Depth 28"
Height 31"
Seating Depth 21"
Seating Height 17"





SKU: ROYALTY 99 SOFA



PRODUCT SPECIFICATIONS

Designed for both style and functionality, our sofa seamlessly combines modern aesthetics with timeless charm. Its brass nailhead outline, carefully tailored stitching, and graceful silhouette effortlessly blend into any decor scheme, making it a versatile focal point of any hospitality space. The ROYALTY collection responds to the realities of lounging and the rigors of everyday use in high traffic area, a perfect addition to any hospitality space. Brass nailhead outline provides alluring sophistication. This sofa will give your establishment or event an exclusive design with commercial grade quality.

Length 99"
Depth 28"
Height 31"
Seating Depth 21"
Seating Height 17"





SKU: CHICAGO SOFA



PRODUCT SPECIFICATIONS

The CHICAGO Sofa redefines modern seating with a seamless blend of three key materials: a sleek gunmetal frame, premium Formica base, and in-viting soft seating. Designed for durability and style, this commercial-grade sofa offers a clean, uniform look ideal for reception areas, lounges, and public spaces. Equipped with optional integrated charging stations, the CHICAGO ensures guests stay powered up while relaxing in comfort. Its refined design not only enhances any contemporary environment but also provides exceptional support for daily use. Crafted in the USA, the CHICAGO Sofa is the perfect blend of form, function, and sophisticated style.

Length 48" or 73"
Depth 27"
Height 37"
Seating Depth 20"
Seating Height 18"





SKU: PATTY SOFA



PRODUCT SPECIFICATIONS

This boutique-style sofa embodies refined elegance and modern sophistication, inspired by the luxurious designs seen in the lobby of The Breakers Hotel in Palm Beach, FL and many other Boutique Hotels. Its gracefully sloped arms and high back create an inviting silhouette that seamlessly blends style and comfort. Crafted with premium upholstery and supported by a solid metal frame, this piece exudes durability and charm, perfect for boutique hotel lobbies, exclusive lounges, and high-end public spaces. The clean lines and sculpted profile elevate any setting, while plush seating ensures lasting comfort for guests.

Length 72"
Depth 32"
Height 43.5"
Seating Depth 23"
Seating Height 18"





SKU: SAVANNAH CHAIR



PRODUCT SPECIFICATIONS

The SAVANNAH Seating collection is designed with the modern educational environment in mind. Bright, inviting, and easy to move, this armless loveseat adapts effortlessly to changing layouts and dynamic spaces. Equipped with discreet casters in the front and sturdy rear handles, the SAVANNAH can be lifted and repositioned with minimal effort — perfect for classrooms, libraries, student lounges, and collaborative work areas. The integrated privacy panels offer visual separation without closing off the room, while built-in USB/110-volt power outlets keep devices charged and users connected. Upholstered in vibrant, easy-to-clean materials, SAVANNAH seating pairs durability with a contemporary look that enhances any space. This smart design promotes mobility, flexibility, and productivity, making it ideal for schools, universities, and public venues. Comfort, style, and adaptability — the SAVANNAH Seating package delivers it all.

How it works: this bright and inviting armless loveseat was created to allow for easy mobility, so it can be either moved to a desired position quickly or out of the way. The front of the loveseat has two casters, so when the sofa is lifted towards the front, by using the rear handles, the loveseat now is able to be easily moved.

- Length: 48"
- Depth: 25.5"
- Height: 36"
- Seating Depth: 19.5"
- Seating Height: 18.5"



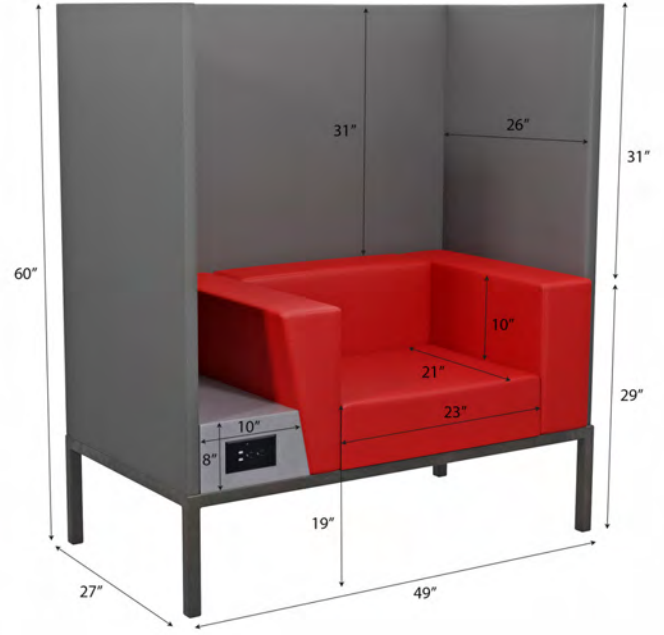

SKU: HF CUBBIE



PRODUCT SPECIFICATIONS

The HF CUBBIE Console Table with USB and 110V outlet is the perfect solution for modern learning and lounge environments. Designed for student lounges, universities, libraries, airports, and corporate spaces, this USA-made piece combines smart design with lasting durability. Built on a fully welded steel frame, it offers a sturdy surface for study or work while integrating built-in USB and 110V power outlets to keep devices charged. Pair it with lounge seating or study capsules to create private, functional spaces that support productivity and comfort. Dura-ble, practical, and stylish — an essential addition for today’s public and student spaces

Console table
 1x Power Outlet has [2x] USB and [2x] 110v ports.
 Width: 10”
 Length: 26”

Chair Dimension:
 Length: 37”
 Depth: 26”
 Height: 29”
 Seating Depth: 21”
 Seating Height: 19”

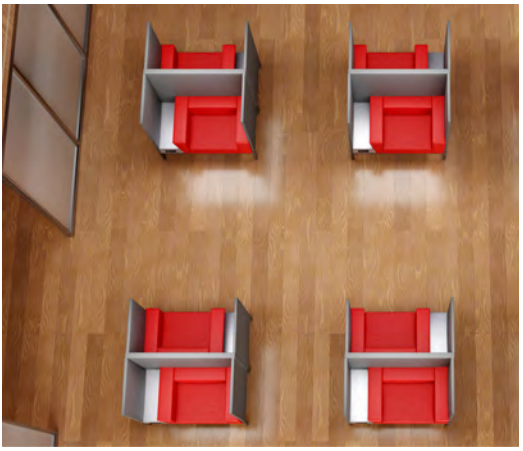



SKU: HF88CB



PRODUCT SPECIFICATIONS

Our fully upholstered Club Chair—often called a bucket chair—is a timeless favorite in the hospitality world, designed for comfort, style, and adaptability. Made in the USA, this versatile seating option has become a staple in clubs, hotels, lounges, restaurants, and other commercial environments where individual comfort and elegant design are key. Its deep seat and supportive curved back offer a cozy, relaxed experience while maintaining a refined appearance that complements any setting. The chair is available with your choice of casters for easy mobility, glides for a stationary setup, or a 360° swivel base for added flexibility. Upholstery options are fully customizable, allowing you to match your brand or interior design vision with ease. Built to commercial-grade standards, it delivers long-term durability and comfort your guests will notice. Whether used as lounge seating, dining accents, or in waiting areas, this chair creates a premium, individualized seating experience.

- Width: 29.5"
- Depth: 30"
- Height: 34"
- Seating Height: 18"
- Seating Depth: 20"

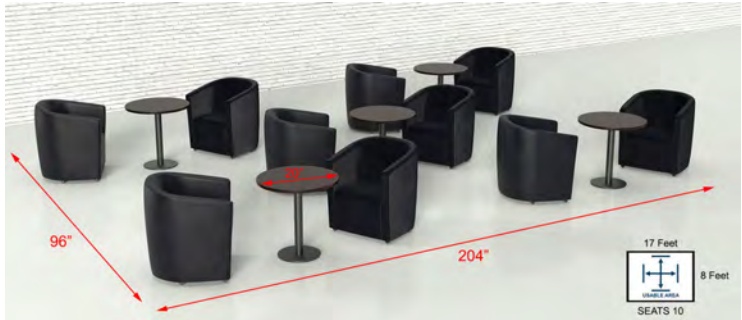



SKU: HF20CB



PRODUCT SPECIFICATIONS

Bold, compact, and built for comfort, this fully upholstered commercial-grade club chair is a standout piece in any hospitality environment. This model brings high-impact color and lasting performance to lounges, hotel lobbies, offices, and public waiting areas. The curved “bucket” silhouette cradles the body with comfort and support, making it an ideal choice for individual seating that still makes a design statement. Built in the USA with a fully upholstered frame and seamless seat design, this chair is available with casters (as shown), glides, or a 360° swivel base for added flexibility. The internal frame is engineered for heavy-duty commercial use with a weight capacity over 350 lbs. Custom upholstery options and configurations are available to suit your space. Whether you’re outfitting a full lounge or adding accent seating, this chair delivers timeless comfort with a modern edge.

Length 30”

Depth: 28”

Height: 35”

Seating Height: 18”

Seating Depth: 20”





SKU: HFLX CHAIR



PRODUCT SPECIFICATIONS

This beautiful club chair is custom built in USA. Luxurious and handmade chair will give your establishment or event an exclusive design with commercial grade quality. Built to be both lightweight and sturdy - designed to be used in high traffic areas. Frame is built of solid hardwood. Cushion is made of high density CAL 117 certified foam. Joints are glued, stapled and screwed to ensure frame stability and longevity. Stands on non-marring floor glides.

Width: 28"
Depth: 25.5"
Height: 30"
Seating Height: 18"
Seating Depth: 20.5"





SKU: HF2037CC



PRODUCT SPECIFICATIONS

This product can be custom made to match your specs or reupholstered in a variety of colors and textures within a few business days. Brass nailhead trim compliments the luxurious style of button tufted design. Contrast of curved design features and clean lines will give your establishment or event an exclusive modern design with commercial grade quality. Durable construction materials include solid hardwood frames, high density foam and heavy gauge steel. Chair sits on heavy duty black metal legs. Features beautiful, smooth and semi-glossy leather grain pattern. Excellent performance commercial grade-vinyl with 100,000 double rubs. HF2037CC upholstery is also Phthalate free and Lead free. It is California TB 117 fire code certified.

Length 30"
Depth: 25"
Height: 30"
Seating Height: 17.5"
Seating Depth: 20"





SKU: CHARLOTTE Z CHAIR



PRODUCT SPECIFICATIONS

Introducing the CHARLOTTE Z CHAIR — a perfect fusion of comfort, durability, and standout style. Designed and manufactured in the USA, this modern club chair features a unique “slide and glide” armrest design that offers continuous support from the shoulder to the palm, creating a truly ergonomic experience. The sleek, structured frame is supported by 4” fully welded metal legs, giving it a bold stance and impressive 350+ lb weight capacity, ideal for high-traffic commercial spaces. Upholstered in premium materials with meticulous tailoring, the CHARLOTTE Z brings a sophisticated look to hospitality lounges, restaurants, hotels, and upscale waiting areas. Its strong silhouette and thoughtful comfort make it more than just a seat — it’s a visual and functional anchor for any room. With the CHARLOTTE Z, your space will command attention while delivering lasting performance and relaxation.

Width: 27”

Depth: 27”

Height: 32”

Seating Height 17”

Seating Depth: 20”

Each Arm: 3”





SKU: CHARLOTTE X CHAIR



PRODUCT SPECIFICATIONS

Crafted with premium upholstery and supported by a solid metal frame, this piece exudes durability and charm, perfect for boutique hotel lobbies, exclusive lounges, and high-end public spaces. The clean lines and sculpted profile elevate any setting, while plush seating ensures lasting comfort for guests. Chair's frame is made from solid wood. Base frame is made from 1" carbon steel powder coated gunmetal finish. Cushions are made of high density CAL 117 certified foam. Joints are glued, stapled and screwed to ensure frame stability and longevity.

Length: 27"

Depth: 27"

Height: 32"

Seating Depth: 20"

Seating Height: 18"

Each Arm: 3"





SKU: MIAMI CHAIR



PRODUCT SPECIFICATIONS

Built to be sturdy, pieces can be transported with ease and used in high traffic areas.

Upholstered banquette seating with deep soft cushioned padding for the most comfort and support

Frame is made from solid wood. Cushions are made of high density CAL 117 certified foam. Super high-performance commercial grade vinyl featuring 500,000 double rubs, California and Boston fire codes certifications. Common applications in hospitality, healthcare, contract, education, marine and automotive industries.

Gunmetal powder coated carbon steel frame is fully welded - built to be used in high traffic areas.

Length: 27"

Depth: 27"

Height: 31"

Seating Depth: 21"

Seating Height: 16.5"

Each Arm: 3"



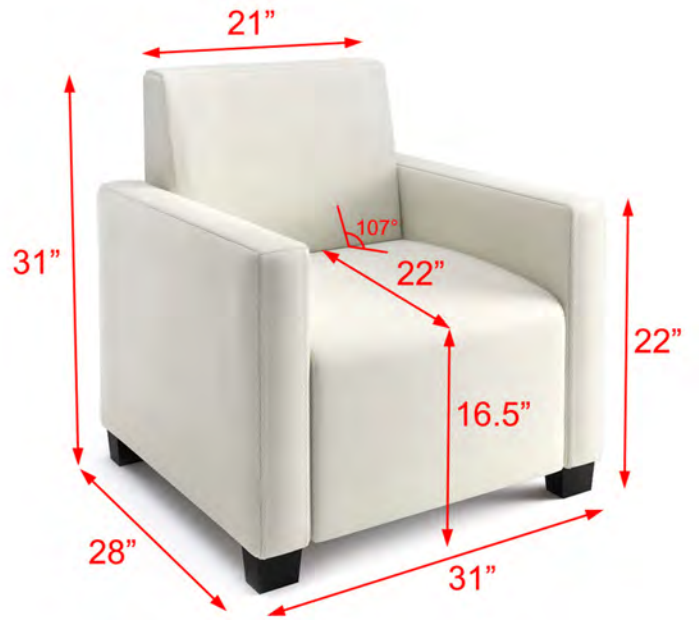

SKU: OHIO CHAIR



PRODUCT SPECIFICATIONS

Built to be sturdy, pieces can be transported with ease and used in high traffic areas.

Upholstered banquette seating with deep soft cushioned padding for the most comfort and support

Frame is made from solid wood. Cushions are made of high density CAL 117 certified foam. Super high-performance commercial grade vinyl featuring 500,000 double rubs, California and Boston fire codes certifications. Common applications in hospitality, healthcare, contract, education, marine and automotive industries.

Width 31"

Depth 28"

Height 31"





SKU: HFT5 CHAIR



PRODUCT SPECIFICATIONS

Uniquely crafted, with Modern mid century style and exceptional comfort as its forte, Our HFT5 Collection effortlessly finds its place in corporate lobbies, healthcare environments, hospitality lounges and more. Modular seating configurations for any open space areas will provide maximum seating potential while showing its style as a stand-alone Sofa or Chairs, that serves any number of purposes.

Length: 36"
Depth: 27"
Height: 27"
Seating Height 18"
Seating Depth: 23"
Cushion Arms & Back Thickness: 4.75"





SKU: LAPTOP CHAIR



PRODUCT SPECIFICATIONS

Whether in lobbies or public areas, or casual meeting environments and touchdown spaces, This Modern Commercial chair abounds with possibilities. Lounge chairs with casters or Metal Frame make an excellent choice for workgroups – the ever growing collaborative work style. Rotating tablet or pull-up table and Heavy duty commercial and functional chair becomes the gateway to productive freedom. Yet for all its functionality, Scania is equally pleasing in traditional lounge settings where simply waiting in comfort is all that is required.

Length: 27"

Depth: 27"

Height: 34"

Seating Depth: 21"

Seating Height: 18"

Each Arm: 3"





SKU: WING CHAIR



PRODUCT SPECIFICATIONS

This boutique-style sofa embodies refined elegance and modern sophistication, inspired by the luxurious designs seen in the lobby of The Breakers Hotel in Palm Beach, FL and many other Boutique Hotels. Its gracefully sloped arms and high back create an inviting silhouette that seamlessly blends style and comfort. Crafted with premium upholstery and supported by a solid metal frame, this piece exudes durability and charm, perfect for boutique hotel lobbies, exclusive lounges, and high-end public spaces. The clean lines and sculpted profile elevate any setting, while plush seating ensures lasting comfort for guests.

Width: 37.5"
Depth: 28"
Height: 28"
Seating Height 17.5"
Seating Depth: 21"





SKU: WING AIR CHAIR



PRODUCT SPECIFICATIONS

Whether in lobbies or public areas, or casual meeting environments and touchdown spaces, This Modern Commercial chair abounds with possibilities. Lounge chairs with casters or Metal Frame make an excellent choice for workgroups – the ever growing collaborative work style. Rotating tablet or pull-up table and Heavy duty commercial and functional chair becomes the gateway to productive freedom. Yet for all its functionality, Scania is equally pleasing in traditional lounge settings where simply waiting in comfort is all that is required.

Center console table

Laminate features fire resistance Stain, scratch and impact resistant.

1x Power Outlet has [2x] USB and [2x] 110v ports.

Width: 13"

Length: 27"

Chair Dimension:

Length: 37.5"

Depth: 27"

Height: 28"

Seating Depth: 21"

Seating Height: 17.5"





SKU: HIDEAWAY CHAIR



PRODUCT SPECIFICATIONS

The HIDEAWAY collection responds to the realities of lounging and the rigors of everyday use in high traffic area, a perfect addition to any hospitality space. Designed for both style and functionality, our chair seamlessly combines modern aesthetics with timeless charm. Its brass railhead outline, carefully tailored stitching, and graceful silhouette effortlessly blend into any decor scheme, making it a versatile focal point of any hospitality space. The HIDEAWAY collection responds to the realities of lounging and the rigors of everyday use in high traffic area, a perfect addition to any hospitality space.

Length 41"
Width 29"
Height 31"
Seating Depth 20.5"
Seating Height 17.5





SKU: TRENTON CHAIR



PRODUCT SPECIFICATIONS

The TRENTON Chair offers a fresh, modern twist on classic club seating, making it a favorite for restaurants, lounges, hotels, and other hospitality spaces. With its sleek lines and bold silhouette, this chair adds a contemporary edge to any environment while prioritizing guest comfort. Upholstered in premium materials and handcrafted in the USA, the TRENTON Chair pairs a sophisticated look with commercial-grade durability. The ergonomic design provides ample back and arm support, ensuring guests can relax in style. Its robust frame and high-density foam cushions stand up to the rigors of daily use in high-traffic spaces, offering hospitality comfort and durability for any application with a 350 lb weight capacity. TRENTON Chair delivers form and function in perfect balance.

Width: 36"
Depth: 27"
Height: 28"
Seating Height 17.5"
Seating Depth: 21"
Each Arm: 6"





SKU: KEYS CHAIR



PRODUCT SPECIFICATIONS

Built to be sturdy, pieces can be transported with ease and used in high traffic areas.

Upholstered banquette seating with deep soft cushioned padding for the most comfort and support

Frame is made from solid wood. Cushions are made of high density CAL 117 certified foam. Super high-performance commercial grade vinyl featuring 500,000 double rubs, California and Boston fire codes certifications. Common applications in hospitality, healthcare, contract, education, marine and automotive industries.

Length: 32"

Depth: 28"

Height: 32"

Seating Depth: 20"

Seating Height: 15.5"





SKU: VENICE BEACH CHAIR



PRODUCT SPECIFICATIONS

The Venice Beach Chair bridges modern sophistication with timeless tradition, making it the ideal furniture seating solution for restaurants, lounges, hotel lobbies, and upscale hospitality spaces. Its sleek metal frame provides reliable structural support and a contemporary look, while the generously upholstered seat and unique back and armrest design offer unparalleled comfort. This chair's deep seating and plush cushions create a relaxed and restful experience, inviting guests to linger longer. The durable gunmetal frame ensures stability and longevity, perfect for high-traffic commercial settings. Experience the best of both worlds — the Venice Beach Chair delivers traditional comfort with a modern twist, elevating any space with style and substance.

Length 32"
Width 28"
Height 32"
Seating Depth 21.5"
Seating Height 17"





SKU: PATTY CHAIR



PRODUCT SPECIFICATIONS

Built to be sturdy, pieces can be transported with ease and used in high traffic areas.

Upholstered banquette seating with deep soft cushioned padding for the most comfort and support

Frame is made from solid wood. Cushions are made of high density CAL 117 certified foam. Super high-performance commercial grade vinyl featuring 500,000 double rubs, California and Boston fire codes certifications. Common applications in hospitality, healthcare, contract, education, marine and automotive industries.

Length 37"

Depth 32"

Height 43.5"

Seating Depth 23"

Seating Height 18"

Seat 23" x 30"





SKU: KENTUCKY KING CHAIR



PRODUCT SPECIFICATIONS

This tufted pub chair is the perfect complement to our 36" and 96" whiskey barrel tables, completing the look of your rustic-inspired space with comfort and style. The base is finished in our signature Walnut, Salvaged Planked Elm or Bourbon Pine laminate and many others, replicating the warmth and texture of aged whiskey barrels. Above, a plush, upholstered seat and button-tufted diamond-stitched backrest elevate the piece into a luxurious yet approachable seating option. The contrast of rich woodgrain and refined upholstery makes this chair truly unique — where comfort meets tradition. Whether you're designing for a pub, brewery, distillery, or themed bar, this chair brings cohesion, personality, and commercial-grade durability to any environment. Handcrafted in the USA and built to perform.

Width: 26"

Depth: 27"

Height: 36"

Seating Height: 16"

Seating Depth: 20"





SKU: SHORT TRENTON OTTOMAN



PRODUCT SPECIFICATIONS

The SHORT TRENTON Ottoman adds versatility to any modular lounge setting — whether used as a footrest, standalone seat, or table surface. Its simple rectangular form and clean lines match the full SHORT TRENTON lineup, making it easy to integrate into straight or curved layouts. The elevated leg frame ensures modern appeal and easy cleaning access underneath. This piece is ideal for hospitality lounges, retail environments, and corporate settings where functionality and design matter. Built in the USA with premium materials, the SHORT TRENTON Ottoman completes your modular vision with flexible style.

Length: 48"
Width: 27"
Height: 17.5"





SKU: TRENTON XBN



PRODUCT SPECIFICATIONS

TRENTON is a modern modular collection, which is well tailored for superb comfort. TRENTON collection provides perfect contemporary seating solutions for public spaces in your high traffic environment. Carbon steel frame is fully welded with a gunmetal powder coated finish.

Length: 27', 48", 60' or 73"
Depth: 27"
Height 18"





SKU: HF85 OTTOMAN



PRODUCT SPECIFICATIONS

The HF85 Round Ottoman is the perfect companion to your curved seating setup. At 38" wide, it offers generous surface area as a footrest, drink table, or accent centerpiece. Upholstered for comfort and crafted for durability, this commercial-grade ottoman adds utility and style to hospitality lounges, hotel lobbies, and VIP settings.

Ottoman: Diameter 38" | Height 17"





SKU: HF87 OTTOMAN



PRODUCT SPECIFICATIONS

The HF87 Round Ottoman is the perfect companion to your curved seating setup. At 60" wide, it offers generous surface area as a footrest, drink table, or accent centerpiece. Upholstered for comfort and crafted for durability, this commercial-grade ottoman adds utility and style to hospitality lounges, hotel lobbies, and VIP settings.

Ottoman: Diameter 60" | Height 17"





SKU: CHICAGO BENCH



PRODUCT SPECIFICATIONS

Ideally this Modern Laminate and Upholstery Style Bench is suited for open space Hotel Lobby, healthcare, education, retail environments and much more, this Alta collection has plenty of style and comfort. With its Modern Contemporary Metal and Laminate Wood frame design, Upholstery, Fabric and stitching details, the Alta Bench is perfect on its own or as a complement to any seating arrangement. Offered in two and three seat versions, with a choice of gunmetal frame, and many laminate options this model makes a statement in any lobby or open space area. Charging your gadgets devices would be another feature on both sides of the bench.

Bench: Length 73" | Depth 27" | Height 18"



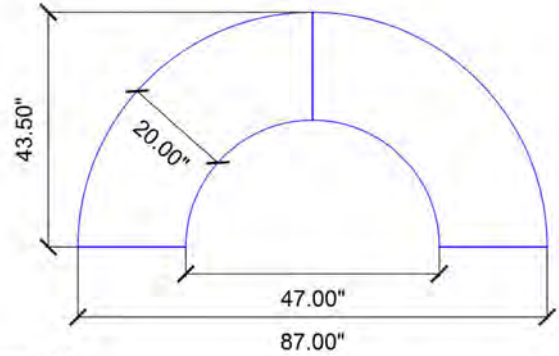

Contains: 2 Tails

SKU: THE CONVERTIBLE



PRODUCT SPECIFICATIONS

Built to be sturdy, pieces can be transported with ease and used in high traffic areas.

Upholstered banquette seating with deep soft cushioned padding for the most comfort and support

Frame is made from solid wood. Cushions are made of high density CAL 117 certified foam. Super high-performance commercial grade vinyl featuring 500,000 double rubs, California and Boston fire codes certifications. Common applications in hospitality, healthcare, contract, education, marine and automotive industries.

Each Tail Component: Length: 43.50" | Seating Width: 20" | Seating Height 18"



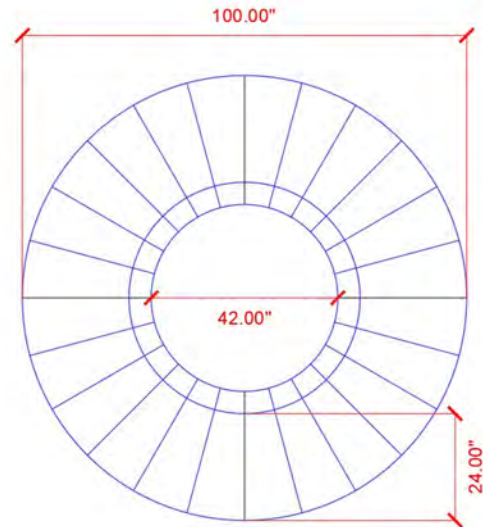

SKU: ROUNDABOUT



PRODUCT SPECIFICATIONS

The ROUNDABOUT Center Settee is where luxury meets modern craftsmanship. Designed for hotel lobbies, grand entrances, and public spaces, this elegant round seating unit brings a statement of sophistication to any environment. Featuring a railroad channel-back design, Rotonda delivers both comfort and architectural beauty — ensuring every lobby shines like a star.

This modular center-round banquette is handcrafted in the USA with premium materials and commercial-grade construction to withstand high-traffic areas. Its 100” circular design allows guests to gather, relax, and socialize in style. The ROUNDABOUT’s versatility allows it to be upholstered in any fabric or vinyl, and can be customized into stunning two-tone combinations to complement any interior aesthetic.

Pair it with our marble-top tables and coordinated modular lounge seating to create a cohesive, inviting atmosphere that blends hospitality and high-end design. Ideal for front-of-house areas, hallways, and hotel reception zones, the ROUNDABOUT series redefines what modern lobby seating should be — elegant, durable, and unmistakably comfortable.

- Round 100”
- Height 46”
- Seating Depth 24”
- Seating Height 18”



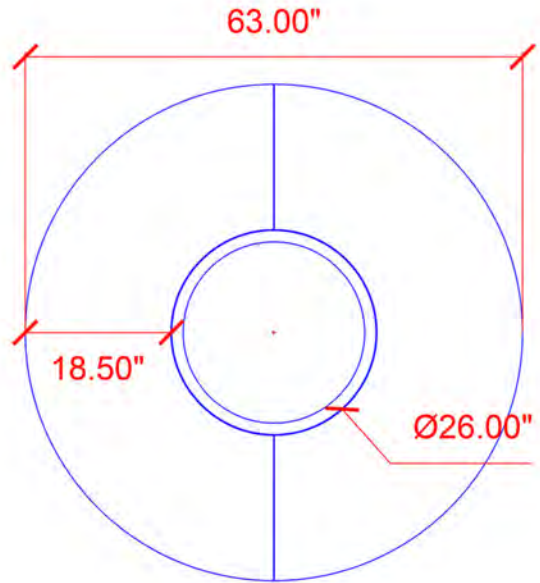

SKU: THE BUOY



PRODUCT SPECIFICATIONS

One of our most popular event-suited seating tower that brings a modern appeal with a center-piece presentation that will surely catch the eye. The button-tufting upholstery adds a luxurious feel and look; while the modular design provides the ease of mobility.

Built to be sturdy, pieces can be transported with ease and used in high traffic areas.

Upholstered banquette seating with deep soft cushioned padding for the most comfort and support

Frame is made from solid wood. Cushions are made of high density CAL 117 certified foam. Super high-performance commercial grade vinyl featuring 500,000 double rubs, California and Boston fire codes certifications. Common applications in hospitality, healthcare, contract, education, marine and automotive industries.

Diameter: 63"

Seating Depth: 18.5"

Seating Height: 17.5"

Overall Height: 45"





SKU: FLAT ATLANTIC BOOTH



PRODUCT SPECIFICATIONS

The FLAT ATLANTIC Booth features a clean, straight backrest that delivers a traditional, no-nonsense aesthetic — ideal for diners, cafés, or casual restaurant settings. Its simple silhouette maximizes seating space and allows for tight wall placement, making it a go-to for efficiency without sacrificing style. The flat back offers a timeless look that blends easily into any interior concept. Built with 4” black legs and a weight capacity of 350 lbs. per seat, it’s made in the USA for lasting durability. This budget-friendly booth connects easily in a line, offering both practicality and understated charm.

Built to be sturdy, pieces can be transported with ease and used in high traffic areas. Upholstered banquette seating with deep soft cushioned padding for the most comfort and support. Frame is made from solid wood. Cushions are made of high density CAL 117 certified foam. Super high-performance commercial grade vinyl featuring 500,000 double rubs, California and Boston fire codes certifications. Common applications in hospitality, healthcare, contract, education, marine and automotive industries.

- Length 48” or 60”
- Width 24.5” (Single), 48” (Double)
- Height 36” or 42”
- Seating Depth 19”
- Seating Height 18”





SKU: ATLANTIC CHANNEL BOOTH



PRODUCT SPECIFICATIONS

Designed with vertical stitched channels, the FLAT ATLANTIC Booth gives off a polished, “classic restaurant” vibe — reminiscent of upscale diners and modern American eateries. The channeling provides subtle contour and visual height, adding a structured, tailored look that suits dining rooms aiming for an inviting yet refined feel. It’s the perfect middle ground between minimal and luxurious. Mounted on 4” black legs with a 350 lb. weight capacity per seat, it’s easy to configure in long runs and built to last. Proudly made in the USA with performance-grade materials and commercial durability.

Built to be sturdy, pieces can be transported with ease and used in high traffic areas.

Upholstered banquette seating with deep soft cushioned padding for the most comfort and support. Frame is made from solid wood. Cushions are made of high density CAL 117 certified foam. Super high-performance commercial grade vinyl featuring 500,000 double rubs, California and Boston fire codes certifications. Common applications in hospitality, healthcare, contract, education, marine and automotive industries.

Length 48” or 60”

Width 24.5” (Single), 48” (Double)

Height 36” or 42”

Seating Depth 19”

Seating Height 18”





SKU: ATLANTIC DIAMOND BOOTH



PRODUCT SPECIFICATIONS

The ATLANTIC Diamond Tufted Booth exudes high-end sophistication with its handcrafted diamond-tufted back — a detail often found in luxury lounges, boutique hotels, and elegant dining spaces. This design makes a bold visual statement, instantly elevating the atmosphere and encouraging a more upscale, intimate experience. The deep tufting adds plush comfort and depth, while the sleek frame and 4” black legs complete the modern-luxury look. With 350 lbs. weight capacity per seat and made in the USA, this booth is as durable as it is striking — ideal for clients who want refined design without the custom price tag.

Built to be sturdy, pieces can be transported with ease and used in high traffic areas.

Upholstered banquette seating with deep soft cushioned padding for the most comfort and support

Frame is made from solid wood. Cushions are made of high density CAL 117 certified foam. Super high-performance commercial grade vinyl featuring 500,000 double rubs, California and Boston fire codes certifications. Common applications in hospitality, healthcare, contract, education, marine and automotive industries.

Length 48” or 60”

Width 24.5” (Single), 48” (Double)

Height 36” or 42”

Seating Depth 19”

Seating Height 18”





SKU: SIMPLICITY BANQUETTE



PRODUCT SPECIFICATIONS

The SIMPLICITY BANQUETTE Booth is a go-to choice for modern spaces that value simplicity and clean lines. With its smooth, unembellished back panel, this booth offers a minimalist aesthetic that complements a wide range of restaurant styles — from casual cafés to sleek urban bistros.

Built to be sturdy, pieces can be transported with ease and used in high traffic areas.

Upholstered banquette seating with deep soft cushioned padding for the most comfort and support

Frame is made from solid wood. Cushions are made of high density CAL 117 certified foam. Super high-performance commercial grade vinyl featuring 500,000 double rubs, California and Boston fire codes certifications. Common applications in hospitality, healthcare, contract, education, marine and automotive industries.

Length 48" or 60"

Width 24" (Single), 46" (Double)

Height 36"

Seating Depth 19"

Laminated Base Depth: 18"

Seating Height 18"





SKU: NEW YORK BANQUETTE



PRODUCT SPECIFICATIONS

The NEW YORK BANQUETTE Booth features crisp vertical channels that introduce texture, structure, and a sense of rhythm to your seating layout. Ideal for contemporary restaurants, lounges, and fast-casual concepts, this design adds just the right amount of visual interest without over-powering the space.

Precision-built in the USA with a commercial-grade hardwood frame and customizable upholstery options, this booth blends comfort with eye-catching detail. The vertical channels not only enhance the design — they provide ergonomic support that patrons will appreciate.

Built to be sturdy, pieces can be transported with ease and used in high traffic areas.

Upholstered banquette seating with deep soft cushioned padding for the most comfort and support

Frame is made from solid wood. Cushions are made of high density CAL 117 certified foam. Super high-performance commercial grade vinyl featuring 500,000 double rubs, California and Boston fire codes certifications. Common applications in hospitality, healthcare, contract, education, marine and automotive industries.

Length 48" or 60"

Width 24" (Single), 46" (Double)

Height 36"

Seating Depth 19"

Laminated Base Depth: 18"





SKU: KING BANQUETTE



PRODUCT SPECIFICATIONS

For venues that demand a touch of drama and luxury, the KING BANQUETTE Booth delivers. Featuring deep-set button tufting in a diamond pattern, this design evokes timeless sophistication — perfect for steakhouses, cocktail lounges, and fine dining spaces. Each booth is handcrafted in the USA with a durable hardwood frame, dense foam cushioning, and your choice of commercial-grade fabric or vinyl. The diamond tufting adds depth and texture, making this booth not just seating, but a statement piece.

Upholstered banquette seating with deep soft cushioned padding for the most comfort and support. Frame is made from solid wood. Cushions are made of high density CAL 117 certified foam. Super high-performance commercial grade vinyl featuring 500,000 double rubs, California and Boston fire codes certifications. Common applications in hospitality, healthcare, contract, education, marine and automotive industries.

Premium Formica® or Wilsonart® laminate wraps around the back and the base to create a beautiful and luxurious look. Laminate features stain, scratch and impact resistance. Our lamaintes are available in many finishes to match any decor.

Length 48” or 60”
Width 24” (Single), 46” (Double)
Height 36”
Seating Depth 19”
Seating Height 18”





SKU: SMOOTH SEATING BOOTH



PRODUCT SPECIFICATIONS

The SMOOTH SEATING Booth is available in three distinct back styles — Flat, Channel, and Diamond Tufted — offering a refined look for any restaurant or hospitality setting. Each booth is built in the USA with a durable hardwood frame, high-density foam, and premium laminate base finishes for a clean, modern aesthetic. Each booth is handcrafted in the USA with a durable hardwood frame, dense foam cushioning, and your choice of commercial-grade fabric or vinyl.

Upholstered banquette seating with deep soft cushioned padding for the most comfort and support. Frame is made from solid wood. Cushions are made of high density CAL 117 certified foam. Super high-performance commercial grade vinyl featuring 500,000 double rubs, California and Boston fire codes certifications. Common applications in hospitality, healthcare, contract, education, marine and automotive industries.

Premium Formica® or Wilsonart® laminate wraps around the back and the base to create a beautiful and luxurious look. Laminate features stain, scratch and impact resistance. Our lamaintes are available in many finishes to match any decor.

Length 72" x 96" x 72"	Includes:
Width 24"	[1] 72" Expo Flat Left Side
Height 36"	[1] 72" Expo Flat Right Side
Seating Depth 19"	[1] 48" Expo Flat Booth
Seating Height 18"	

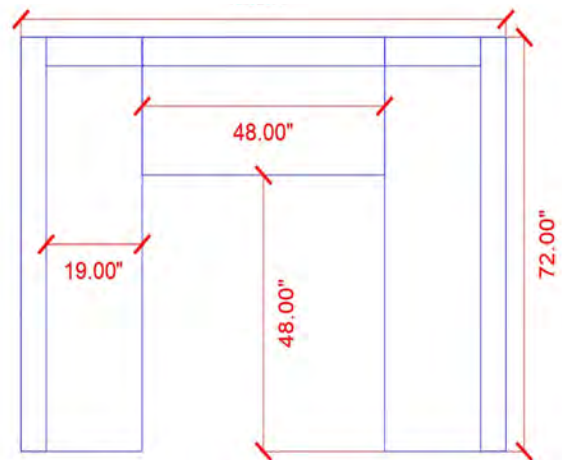



SKU: ROYAL CONVERSATION BOOTH



PRODUCT SPECIFICATIONS

The ROYAL CONVERSATION Booth is available in three distinct back styles — Flat, Channel, and Diamond Tufted — offering a refined look for any restaurant or hospitality setting. Each booth is built in the USA with a durable hardwood frame, high-density foam, and premium laminate base finishes for a clean, modern aesthetic. Each booth is handcrafted in the USA with a durable hardwood frame, dense foam cushioning, and your choice of commercial-grade fabric or vinyl.

Upholstered banquette seating with deep soft cushioned padding for the most comfort and support. Frame is made from solid wood. Cushions are made of high density CAL 117 certified foam. Super high-performance commercial grade vinyl featuring 500,000 double rubs, California and Boston fire codes certifications. Common applications in hospitality, healthcare, contract, education, marine and automotive industries.

Premium Formica® or Wilsonart® laminate wraps around the back and the base to create a beautiful and luxurious look. Laminate features stain, scratch and impact resistance. Our lamaintes are available in many finishes to match any decor.

Length 72" x 96" x 72"	Includes:
Width 24"	[1] 72" Expo Channel Left Side
Height 36"	[1] 72" Expo Channel Right Side
Seating Depth 19"	[1] 48" Expo Channel Booth
Seating Height 18"	

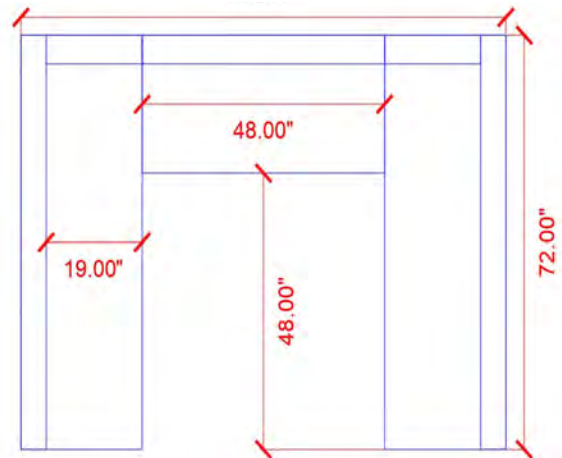



SKU: DUTCHESS CONVERSATION BOOTH

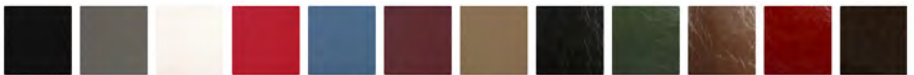

PRODUCT SPECIFICATIONS

The DUTCHESS CONVERSATION Booth is available in three distinct back styles — Flat, Channel, and Diamond Tufted — offering a refined look for any restaurant or hospitality setting. Each booth is built in the USA with a durable hardwood frame, high-density foam, and premium laminate base finishes for a clean, modern aesthetic. Each booth is handcrafted in the USA with a durable hardwood frame, dense foam cushioning, and your choice of commercial-grade fabric or vinyl.

Upholstered banquette seating with deep soft cushioned padding for the most comfort and support. Frame is made from solid wood. Cushions are made of high density CAL 117 certified foam. Super high-performance commercial grade vinyl featuring 500,000 double rubs, California and Boston fire codes certifications. Common applications in hospitality, healthcare, contract, education, marine and automotive industries.

Premium Formica® or Wilsonart® laminate wraps around the back and the base to create a beautiful and luxurious look. Laminate features stain, scratch and impact resistance. Our lamaintes are available in many finishes to match any decor.

- | | |
|------------------------|--|
| Length 72" x 96" x 72" | Includes: |
| Width 24" | [1] 72" Expo Diamond Tufted Left Side |
| Height 36" | [1] 72" Expo Diamond Tufted Right Side |
| Seating Depth 19" | [1] 48" Expo Diamond Tufted Booth |
| Seating Height 18" | |

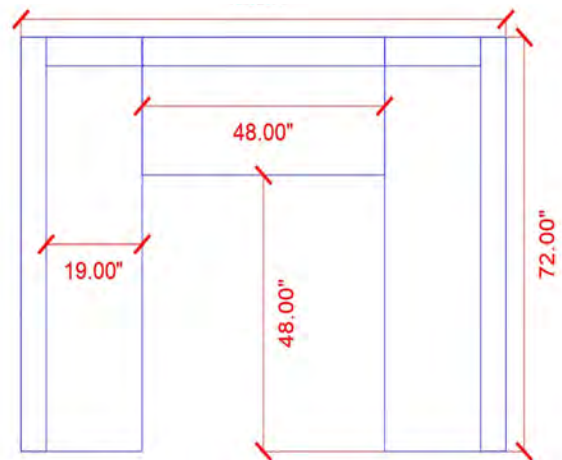



SKU: SIMPLICITY



PRODUCT SPECIFICATIONS

The SIMPLICITY Flat Back Booth offers a clean, streamlined look that blends effortlessly into modern interiors. With its smooth, unstitched back panel, this design is all about simplicity — perfect for restaurant layouts that prioritize a minimalist aesthetic without sacrificing comfort or quality. Its balanced proportions and subtle presence make it an ideal choice for corporate cafeterias, modern steakhouses, or any venue looking for a polished, no-fuss seating solution. Handcrafted in the USA with a durable hardwood frame and black kick base, it's built for long-term commercial use.

Upholstered banquette seating with deep soft cushioned padding for the most comfort and support. Frame is made from solid wood. Cushions are made of high density CAL 117 certified foam. Super high-performance commercial grade vinyl featuring 500,000 double rubs, California and Boston fire codes certifications. Common applications in hospitality, healthcare, contract, education, marine and automotive industries. Premium walnut laminate wraps around the base to create a beautiful and luxurious look. Laminate features stain, scratch and impact resistance. Our laminates are available in many finishes to match any decor.

Length 44"
Width 25"
Height 36"
Seating Depth 20"
Seating Height 18"





SKU: THE KNIGHT

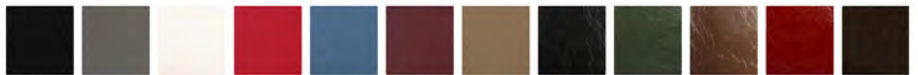

PRODUCT SPECIFICATIONS

Designed to bring dimension and sophistication to any hospitality space, the KNIGHT Channel Back Booth features bold vertical channel stitching that adds depth, texture, and visual interest to the seating experience. It's a perfect match for upscale dining rooms, hotel lounges, or cocktail bars seeking a tailored and luxurious atmosphere. Built in the USA with a solid hardwood frame, plush commercial-grade foam, and your choice of high-performance vinyl or fabric, this booth delivers both comfort and durability. The elegant silhouette is grounded by a classic kick base and refined proportions that invite long, relaxed meals.

Upholstered banquette seating with deep soft cushioned padding for the most comfort and support. Frame is made from solid wood. Cushions are made of high density CAL 117 certified foam. Super high-performance commercial grade vinyl featuring 500,000 double rubs, California and Boston fire codes certifications. Common applications in hospitality, healthcare, contract, education, marine and automotive industries. Premium walnut laminate wraps around the base to create a beautiful and luxurious look. Laminate features stain, scratch and impact resistance. Our laminates are available in many finishes to match any decor.

Length 44"
Width 25"
Height 36"
Seating Depth 20"
Seating Height 18"





SKU: BOSTON BOOTH



PRODUCT SPECIFICATIONS

The BOSTON Booth is one of the most in-demand styles for today's high-end restaurants and steakhouses — and for good reason. Its iconic diamond-tufted backrest with deep-set buttons delivers a rich, elegant look that instantly elevates any dining space. Built in the USA with a solid hardwood frame, plush commercial-grade foam, and your choice of high-performance vinyl or fabric, this booth delivers both comfort and durability. The elegant silhouette is grounded by a classic kick base and refined proportions that invite long, relaxed meals.

Upholstered banquette seating with deep soft cushioned padding for the most comfort and support. Frame is made from solid wood. Cushions are made of high density CAL 117 certified foam. Super high-performance commercial grade vinyl featuring 500,000 double rubs, California and Boston fire codes certifications. Common applications in hospitality, healthcare, contract, education, marine and automotive industries. Premium walnut laminate wraps around the base to create a beautiful and luxurious look. Laminate features stain, scratch and impact resistance. Our laminates are available in many finishes to match any decor.

Length 44"
Width 25"
Height 36"
Seating Depth 20"
Seating Height 18"





SKU: SLEEK DINING BOOTH



PRODUCT SPECIFICATIONS

The SLEEK Flat Back Half-Circle (or 3/4 Circle) Booth offers a clean, uninterrupted silhouette paired with the eye-catching geometry of a radius design. This rounded shape creates a stunning architectural focal point, transforming dining areas with its soft curves and smart layout. Ideal for circular tables, the half-circle format eliminates sharp corners and creates an effortless, walk-in experience. The flat back delivers a minimalist, versatile aesthetic — perfect for restaurants seeking a modern yet understated vibe. Mounted on black legs and built to support 350 lbs. per seat, this USA-made booth combines space-saving efficiency with unforgettable style and comfort.

Length 84" x 42" or 84" x 84"
 Width 25"
 Height 36"
 Seating Depth 20"
 Seating Height 18"

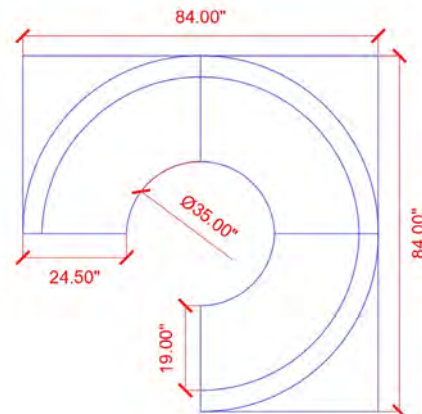
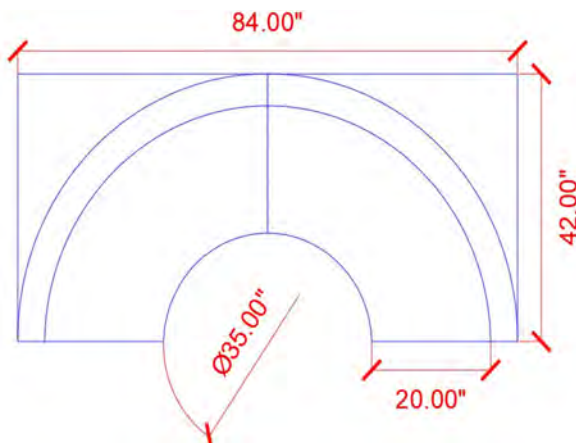



SKU: THE ROYAL



PRODUCT SPECIFICATIONS

With its vertical channel stitching and sweeping curved form, the ROYAL Channel Back Half-Circle (or 3/4 Circle) Booth brings classic restaurant style into a sculptural layout. The radius design allows for natural table flow, avoiding sharp table edges and maximizing guest comfort. This booth instantly becomes the visual anchor of any dining space, drawing attention and defining the room's energy. The structured channel back adds a formal, upright feel that's ideal for restaurants and hospitality venues aiming for a polished, familiar look — with a twist. Proudly made in the USA, each seat supports 350 lbs. and connects effortlessly to create a full layout.

Length 84" x 42" or 84" x 84"
 Width 25"
 Height 36"
 Seating Depth 20"
 Seating Height 18"

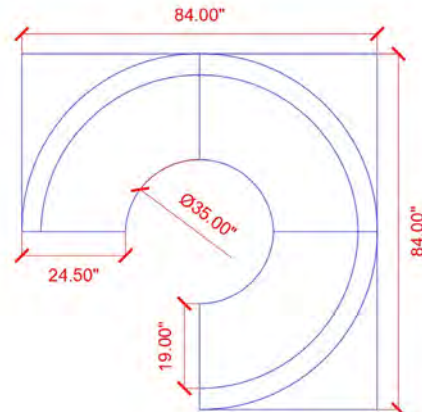
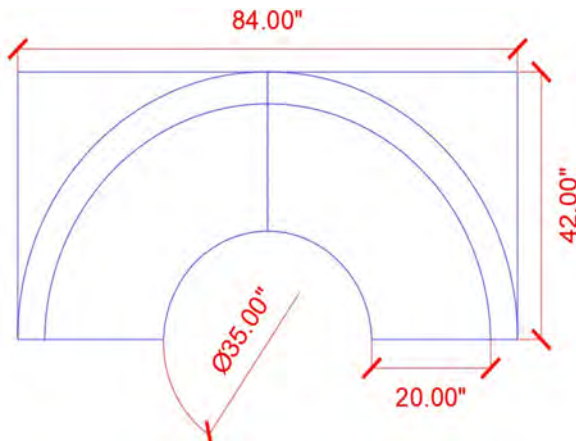



SKU: DUTCHESS



PRODUCT SPECIFICATIONS

The DUTCHESS Diamond Tufted Half-Circle (or 3/4 Circle) Booth makes a luxurious statement with its detailed upholstery and bold radius silhouette. The deep diamond tufting adds dimension and plush sophistication, while the curved half-circle design redefines the entire atmosphere of the room. Perfect for upscale venues, lounges, or boutique restaurants, this booth commands attention as a stunning central feature. Its circular seating invites intimacy and style, while eliminating hard table edges and awkward entry points. Built with 4" black legs and 350 lb. per seat weight capacity, it's handcrafted in the USA for clients who want show-stopping elegance and premium performance.

Length 84" x 42" or 84" x 84"
 Width 25"
 Height 36"
 Seating Depth 20"
 Seating Height 18"

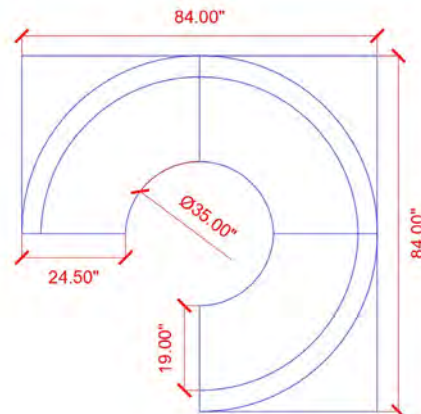
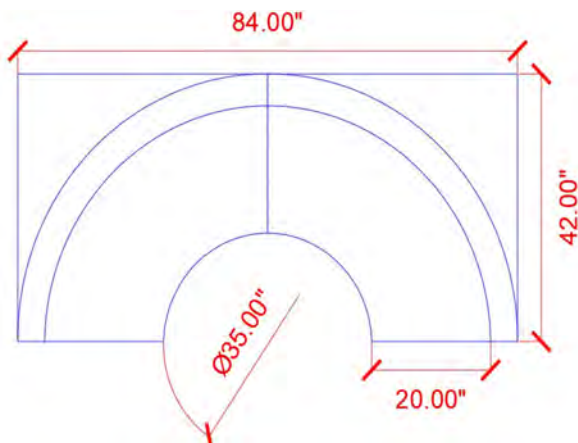



SKU: NEW YORK BOOTH



PRODUCT SPECIFICATIONS

This upscale and sophisticated collection of NEW YORK Single and Double Restaurant booths offers wide seating space and flexibility in dining experience for your restaurant guest. It's designed to meet commercial grade. The Tufted, Channel and Diamond Back panels can be connected to wall divider which will provide privacy and space efficiency in your establishment. Your guest will appreciate the look and unique style of these Modular Restaurant Booths cubicles and will be coming back again.

Built to be sturdy, pieces can be transported with ease and used in high traffic areas. Frame is made from solid wood. Cushions are made of high density CAL 117 certified foam. Super high-performance commercial grade vinyl featuring 500,000 double rubs, California and Boston fire codes certifications. Common applications in hospitality, healthcare, contract, education, marine and automotive industries.

Length 48" or 60"
Width 22" (Single), 41" (Double)
Height 42"
Seating Depth 19"
Seating Height 18"





SKU: CHARLESTON BUTTON BOOTH



PRODUCT SPECIFICATIONS

This upscale and sophisticated collection of CHARLESTON Single and Double Restaurant booths offers wide seating space and flexibility in dining experience for your restaurant guest. It's designed to meet commercial grade. The Tufted, Channel and Diamond Back panels can be connected to wall divider which will provide privacy and space efficiency in your establishment. Your guest will appreciate the look and unique style of these Modular Restaurant Booths cubicles and will be coming back again.

Built to be sturdy, pieces can be transported with ease and used in high traffic areas. Frame is made from solid wood. Cushions are made of high density CAL 117 certified foam. Super high-performance commercial grade vinyl featuring 500,000 double rubs, California and Boston fire codes certifications. Common applications in hospitality, healthcare, contract, education, marine and automotive industries.

- Length 48" or 60"
- Width 22" (Single), 41" (Double)
- Height 42"
- Seating Depth 19"
- Seating Height 18"





SKU: CHARLESTON DIAMOND BOOTH



PRODUCT SPECIFICATIONS

This upscale and sophisticated collection of CHARLESTON Single and Double Restaurant booths offers wide seating space and flexibility in dining experience for your restaurant guest. It's designed to meet commercial grade. The Tufted, Channel and Diamond Back panels can be connected to wall divider which will provide privacy and space efficiency in your establishment. Your guest will appreciate the look and unique style of these Modular Restaurant Booths cubicles and will be coming back again.

Built to be sturdy, pieces can be transported with ease and used in high traffic areas. Frame is made from solid wood. Cushions are made of high density CAL 117 certified foam. Super high-performance commercial grade vinyl featuring 500,000 double rubs, California and Boston fire codes certifications. Common applications in hospitality, healthcare, contract, education, marine and automotive industries.

Length 48" or 60"
Width 22" (Single), 41" (Double)
Height 42"
Seating Depth 19"
Seating Height 18"





SKU: SLEEK BOOTH



PRODUCT SPECIFICATIONS

This upscale and sophisticated collection of Single and Double Restaurant Booths offers wide seating space and flexibility in dining experience for your restaurant guest. It's designed to meet commercial grade. The Flat, Channel and Diamond Back. Your guest will appreciate the look and unique style of these Luxury Traditional Restaurant Booths.

Built to be sturdy, pieces can be transported with ease and used in high traffic areas. Upholstered banquette seating with deep soft cushioned padding for the most comfort and support. Frame is made from solid wood. Cushions are made of high density CAL 117 certified foam. Super high-performance commercial grade vinyl featuring 500,000 double rubs, California and Boston fire codes certifications. Common applications in hospitality, healthcare, contract, education, marine and automotive industries.

- Length (side to side) 48" or 60"
- Height (floor to top) 36" or 48"
- Width 25" (Single), 48" (Double)
- Seating Depth 19.5"
- Seating Height 19"





SKU: ROWED BOOTH



PRODUCT SPECIFICATIONS

This upscale and sophisticated collection of Single and Double Restaurant Booths offers wide seating space and flexibility in dining experience for your restaurant guest. It's designed to meet commercial grade. The Flat, Channel and Diamond Back. Your guest will appreciate the look and unique style of these Luxury Traditional Restaurant Booths.

Built to be sturdy, pieces can be transported with ease and used in high traffic areas.

Upholstered banquette seating with deep soft cushioned padding for the most comfort and support

Frame is made from solid wood. Cushions are made of high density CAL 117 certified foam. Super high-performance commercial grade vinyl featuring 500,000 double rubs, California and Boston fire codes certifications. Common applications in hospitality, healthcare, contract, education, marine and automotive industries.

Length (side to side) 48" or 60"
Height (floor to top) 36" or 48"
Width 25" (Single), 48" (Double)
Seating Depth 19.5"
Seating Height 19"





SKU: SKYE BOOTH



PRODUCT SPECIFICATIONS

This upscale and sophisticated collection of Single and Double Restaurant Booths offers wide seating space and flexibility in dining experience for your restaurant guest. It's designed to meet commercial grade. The Flat, Channel and Diamond Back. Your guest will appreciate the look and unique style of these Luxury Traditional Restaurant Booths.

Built to be sturdy, pieces can be transported with ease and used in high traffic areas.

Upholstered banquette seating with deep soft cushioned padding for the most comfort and support

Frame is made from solid wood. Cushions are made of high density CAL 117 certified foam. Super high-performance commercial grade vinyl featuring 500,000 double rubs, California and Boston fire codes certifications. Common applications in hospitality, healthcare, contract, education, marine and automotive industries.

- Length (side to side) 48" or 60"
- Height (floor to top) 36" or 48"
- Width 25" (Single), 48" (Double)
- Seating Depth 19.5"
- Seating Height 19"





SKU: BUTTON UP BOOTH



PRODUCT SPECIFICATIONS

Durable construction materials include solid hardwood frames build from 2"x3" heavy duty studs, high density foam 1830-1850, durable de-cron and heavy gauge steel. Frame is built of solid hardwood. Cushion is made of high density CAL 117 certified foam. Joints are glued, stapled and screwed to ensure frame stability and longevity. Fully assembled and ready to use.

BUTTON UP Collection Classic: The supple hand and texture of pebble grain leather with Resilience-SR protection. Super high-performance commercial grade-vinyl featuring 500,000 double rubs, California and Boston fire codes certifications.

Glossy Glaze Collection: Features beautiful, smooth and semi-glossy leather grain pattern. Excellent performance commercial grade-vinyl with 100,000 double rubs. Phthalate free and Lead free. It is California TB 117 fire code certified.

Common applications id in hospitality, healthcare, contract, education, marine and automotive industries.

Length: 48" or 60"

Width: 25"

Height: 36" or 48"

Seating Depth: 19.5"

Seating Height: 17"





SKU: FLAT MOON BOOTH



PRODUCT SPECIFICATIONS

Bring effortless elegance to your space with the FLAT MOON Booth — a sleek, curved design that offers both comfort and subtle separation. The smooth backrest delivers a minimalist look ideal for modern restaurants, lounges, or rooftop venues where clean lines matter.

Manufactured in the USA using commercial-grade materials, this booth features a sturdy hardwood frame and customizable upholstery in performance fabric or vinyl. The half-circle layout creates a natural sense of privacy for guests while maximizing floor space. Perfect for open-concept layouts, private dining corners, and upscale modern interiors.

Built to be sturdy, pieces can be transported with ease and used in high traffic areas.

Upholstered banquette seating with deep soft cushioned padding for the most comfort and support

Frame is made from solid wood. Cushions are made of high density CAL 117 certified foam. Super high-performance commercial grade vinyl featuring 500,000 double rubs, California and Boston fire codes certifications. Common applications in hospitality, healthcare, contract, education, marine and automotive industries.

Length 42" by 84" by 42" can accommodate table top up to 36" Round

Length 48" by 96" by 48" can accommodate table top up to 48" Round

Height 36"

Seating Depth 19"

Seating Height 19"

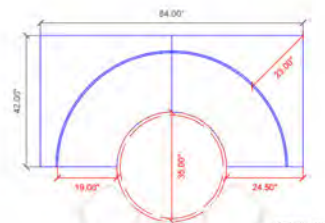

TABLE SIZE: 36"
SEATS 3
SEATS 6 WITH 3 CHAIRS

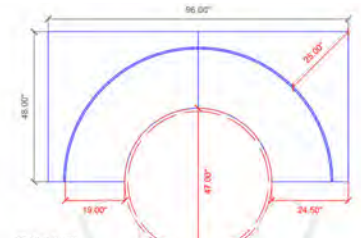

TABLE SIZE: 48"
SEATS 4
SEATS 8 WITH 4 CHAIRS





SKU: CHANNEL MOON BOOTH



PRODUCT SPECIFICATIONS

Add structure and sophistication to your layout with the CHANNEL MOON Booth. This model features vertical channel stitching that delivers rhythm and dimension, creating a rich seating profile that looks as good as it feels.

Ideal for cocktail lounges, hotel bars, or high-end hospitality venues, the booth's curved shape naturally defines space and encourages intimate group seating. Fully customizable and made in the USA, it's the perfect blend of aesthetics and function. A favorite among designers seeking visual texture in a luxury curved form.

Built to be sturdy, pieces can be transported with ease and used in high traffic areas. Upholstered banquette seating with deep soft cushioned padding for the most comfort and support. Frame is made from solid wood. Cushions are made of high density CAL 117 certified foam. Super high-performance commercial grade vinyl featuring 500,000 double rubs, California and Boston fire codes certifications. Common applications in hospitality, healthcare, contract, education, marine and automotive industries.

Length 42" by 84" by 42" can accommodate table top up to 36" Round
 Length 48" by 96" by 48" can accommodate table top up to 48" Round
 Height 36"
 Seating Depth 19"
 Seating Height 19"

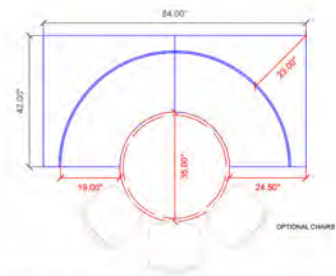

TABLE SIZE: 35"
 SEATS 3
 SEATS 6 WITH 3 CHAIRS

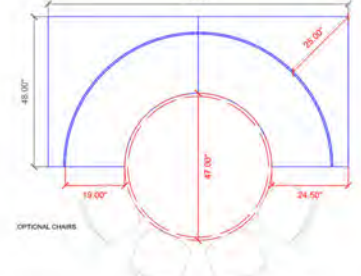

TABLE SIZE: 47"
 SEATS 4
 SEATS 8 WITH 4 CHAIRS





SKU: DIAMOND MOON BOOTH



PRODUCT SPECIFICATIONS

The DIAMOND MOON Booth brings old-world charm to modern spaces. Featuring hand-set button tufting in a diamond pattern, this model turns any seating area into a focal point — combining vintage appeal with commercial-grade durability.

Loved by steakhouses, fine dining restaurants, and VIP lounges, its rounded design gives guests a private, immersive experience while enhancing the room’s elegance. Built with a hardwood frame and tailored in your choice of fabric or vinyl. Elegance in every curve — and craftsmanship in every stitch.

Built to be sturdy, pieces can be transported with ease and used in high traffic areas. Upholstered banquette seating with deep soft cushioned padding for the most comfort and support. Frame is made from solid wood. Cushions are made of high density CAL 117 certified foam. Super high-performance commercial grade vinyl featuring 500,000 double rubs, California and Boston fire codes certifications. Common applications in hospitality, healthcare, contract, education, marine and automotive industries.

Length 42” by 84” by 42” can accommodate table top up to 36” Round
 Length 48” by 96” by 48” can accommodate table top up to 48” Round
 Height 36”
 Seating Depth 19”
 Seating Height 19”

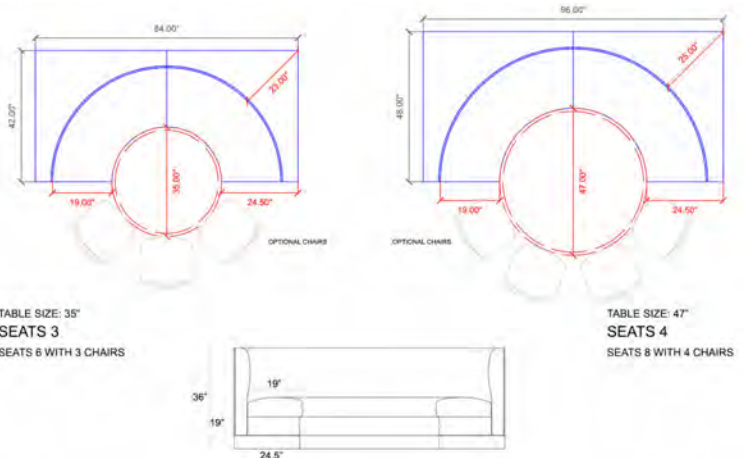



SKU: DINNER SLEEK BOOTH



PRODUCT SPECIFICATIONS

The DINNER SLEEK Booth brings the luxury charm to modern spaces. Featuring hand-set button tufting in a channel pattern, this model turns any seating area into a focal point — combining vintage appeal with commercial-grade durability.

Loved by steakhouses, fine dining restaurants, and VIP lounges, its rounded design gives guests a private, immersive experience while enhancing the room’s elegance. Built with a hardwood frame and tailored in your choice of fabric or vinyl. Elegance in every curve — and craftsmanship in every stitch.

Built to be sturdy, pieces can be transported with ease and used in high traffic areas. Upholstered banquette seating with deep soft cushioned padding for the most comfort and support. Frame is made from solid wood. Cushions are made of high density CAL 117 certified foam. Super high-performance commercial grade vinyl featuring 500,000 double rubs, California and Boston fire codes certifications. Common applications in hospitality, healthcare, contract, education, marine and automotive industries.

Length 48” by 98” by 48”	Includes:
Height 36”	[1] Booth-Flat 48” x 36”H Left Side Extended Corner
Seating Depth 20”	[1] Booth-Flat 48” x 36”H Right Side Extended Corner [1]
Seating Height 19”	[1] Booth-Flat 48” x 36”H Extension

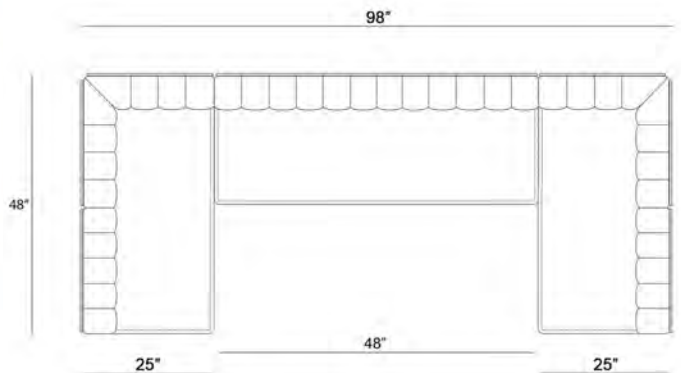



SKU: DINNER CLUB BOOTH



PRODUCT SPECIFICATIONS

The DINNER CLUB Booth brings the luxury charm to modern spaces. Featuring hand-set button tufting in a channel pattern, this model turns any seating area into a focal point — combining vintage appeal with commercial-grade durability.

Loved by steakhouses, fine dining restaurants, and VIP lounges, its rounded design gives guests a private, immersive experience while enhancing the room’s elegance. Built with a hardwood frame and tailored in your choice of fabric or vinyl. Elegance in every curve — and craftsmanship in every stitch.

Built to be sturdy, pieces can be transported with ease and used in high traffic areas. Upholstered banquette seating with deep soft cushioned padding for the most comfort and support. Frame is made from solid wood. Cushions are made of high density CAL 117 certified foam. Super high-performance commercial grade vinyl featuring 500,000 double rubs, California and Boston fire codes certifications. Common applications in hospitality, healthcare, contract, education, marine and automotive industries.

- | | |
|--------------------------|---|
| Length 48” by 98” by 48” | Includes: |
| Height 36” | [1] Booth-Channel 48” x 36”H Left Side Extended Corner |
| Seating Depth 20” | [1] Booth-Channel 48” x 36”H Right Side Extended Corner |
| Seating Height 19” | [1] Booth-Channel 48” x 36”H Extension |

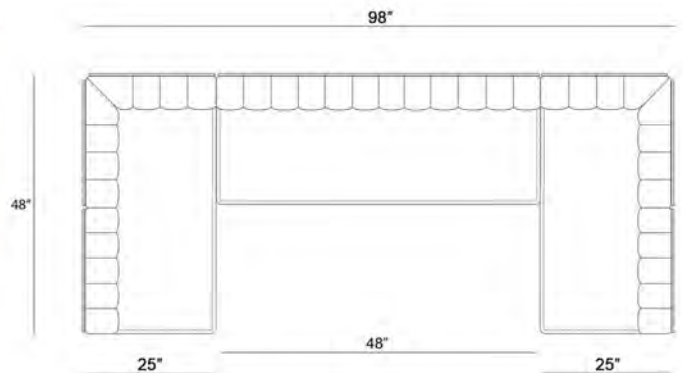



SKU: DINNER LOUNGE BOOTH



PRODUCT SPECIFICATIONS

The DINNER LOUNGE Booth brings the luxury charm to modern spaces. Featuring hand-set button tufting in a channel pattern, this model turns any seating area into a focal point — combining vintage appeal with commercial-grade durability.

Loved by steakhouses, fine dining restaurants, and VIP lounges, its rounded design gives guests a private, immersive experience while enhancing the room’s elegance. Built with a hardwood frame and tailored in your choice of fabric or vinyl. Elegance in every curve — and craftsmanship in every stitch.

Built to be sturdy, pieces can be transported with ease and used in high traffic areas. Upholstered banquette seating with deep soft cushioned padding for the most comfort and support. Frame is made from solid wood. Cushions are made of high density CAL 117 certified foam. Super high-performance commercial grade vinyl featuring 500,000 double rubs, California and Boston fire codes certifications. Common applications in hospitality, healthcare, contract, education, marine and automotive industries.

- | | |
|--------------------------|---|
| Length 48” by 98” by 48” | Includes: |
| Height 36” | [1] Booth-Diamond 48” x 36”H Left Side Extended Corner |
| Seating Depth 20” | [1] Booth-Diamond 48” x 36”H Right Side Extended Corner |
| Seating Height 19” | [1] Booth-Diamond 48” x 36”H Extension |

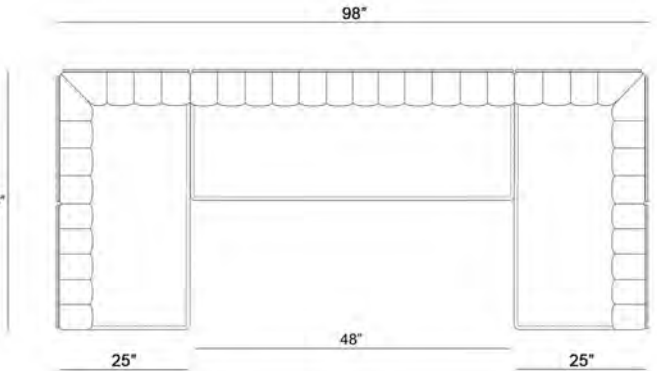



SKU: SLEEK CONVERSATION BOOTH



PRODUCT SPECIFICATIONS

The SLEEK CONVERSATION Booth is a true design centerpiece, offering rich visual texture and a plush, upscale ambiance. The deeply tufted back panels bring luxury and elegance to any setting, while the fully enclosed, upholstered base allows your selected color to flow seamlessly from wall to seating — enhancing brand identity and décor harmony. Designed to seat six around all four sides of the table, this booth delivers both function and statement-making presence. For a perfect fit and clean entry, we recommend pairing it with our CNC-cut custom tables, precisely measured to match the booth's entrance. When ordered together, the booth and table become a unified architectural element, handcrafted in the USA for lasting style and performance.

Built to be sturdy, pieces can be transported with ease and used in high traffic areas. Upholstered banquette seating with deep soft cushioned padding for the most comfort and support. Frame is made from solid wood. Cushions are made of high density CAL 117 certified foam. Super high-performance commercial grade vinyl featuring 500,000 double rubs, California and Boston fire codes certifications. Common applications in hospitality, healthcare, contract, education, marine and automotive industries.

Length 48" by 98" by 98" by 48"
 Height 36"
 Seating Depth 19"
 Seating Height 19"

Includes:
 [2] Booth-34-Circle-Flat 48"L Extensions
 [1] Booth-34-Circle-Flat 48"L Left Extension
 [1] Booth-34-Circle-Flat 48"L Right Extension
 [1] Booth-34-Circle-Flat Corner

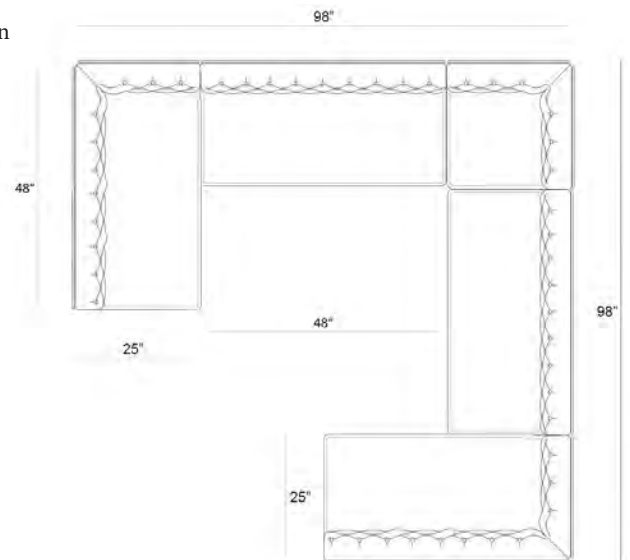



SKU: CONVERSATION BOOTH



PRODUCT SPECIFICATIONS

The CONVERSATION Booth brings texture, order, and adaptability to any commercial dining environment. With vertical channel stitching and fully upholstered back panels, this booth creates a visually structured backdrop that blends beautifully with surrounding interior finishes. The radius layout invites guests to sit around all four sides while maintaining a comfortable, semi-private atmosphere. Every unit is modular, with configurable benches that adapt to your floor plan. Pair it with our CNC-machined custom tables, crafted to fit the booth's entry opening with exact precision. Matching tables ensure smoother access and design cohesion — making this booth-and-table pairing the smart choice for hospitality professionals.

Built to be sturdy, pieces can be transported with ease and used in high traffic areas. Upholstered banquette seating with deep soft cushioned padding for the most comfort and support. Frame is made from solid wood. Cushions are made of high density CAL 117 certified foam. Super high-performance commercial grade vinyl featuring 500,000 double rubs, California and Boston fire codes certifications. Common applications in hospitality, healthcare, contract, education, marine and automotive industries.

Length 48” by 98” by 98” by 48”
 Height 36”
 Seating Depth 19”
 Seating Height 19”

- Includes:
- [2] Booth-34-Circle-Channel 48”L Extensions
 - [1] Booth-34-Circle-Channel 48”L Left Extension
 - [1] Booth-34-Circle-Channel 48”L Right Extension
 - [1] Booth-34-Circle-Channel Corner

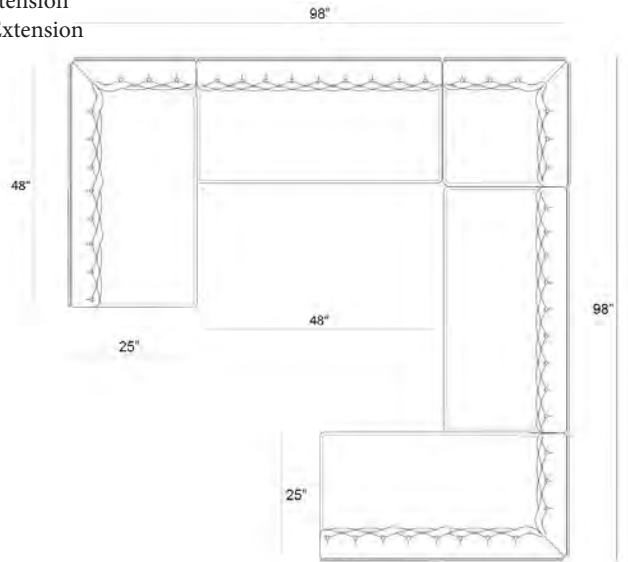



SKU: PRINCESS CONVERSATION BOOTH



PRODUCT SPECIFICATIONS

The PRINCESS CONVERSATION Booth is a true design centerpiece, offering rich visual texture and a plush, upscale ambiance. The deeply tufted back panels bring luxury and elegance to any setting, while the fully enclosed, upholstered base allows your selected color to flow seamlessly from wall to seating — enhancing brand identity and décor harmony. Designed to seat six around all four sides of the table, this booth delivers both function and statement-making presence. For a perfect fit and clean entry, we recommend pairing it with our CNC-cut custom tables, precisely measured to match the booth's entrance. When ordered together, the booth and table become a unified architectural element, hand-crafted in the USA for lasting style and performance.

Built to be sturdy, pieces can be transported with ease and used in high traffic areas. Upholstered banquette seating with deep soft cushioned padding for the most comfort and support. Frame is made from solid wood. Cushions are made of high density CAL 117 certified foam. Super high-performance commercial grade vinyl featuring 500,000 double rubs, California and Boston fire codes certifications. Common applications in hospitality, healthcare, contract, education, marine and automotive industries.

Length 48" by 98" by 98" by 48"
 Height 36"
 Seating Depth 19"
 Seating Height 19"

- Includes:
- [2] Booth-34-Circle-Diamond 48"L Extensions
 - [1] Booth-34-Circle-Diamond 48"L Left Extension
 - [1] Booth-34-Circle-Diamond 48"L Right Extension
 - [1] Booth-34-Circle-Diamond Corner

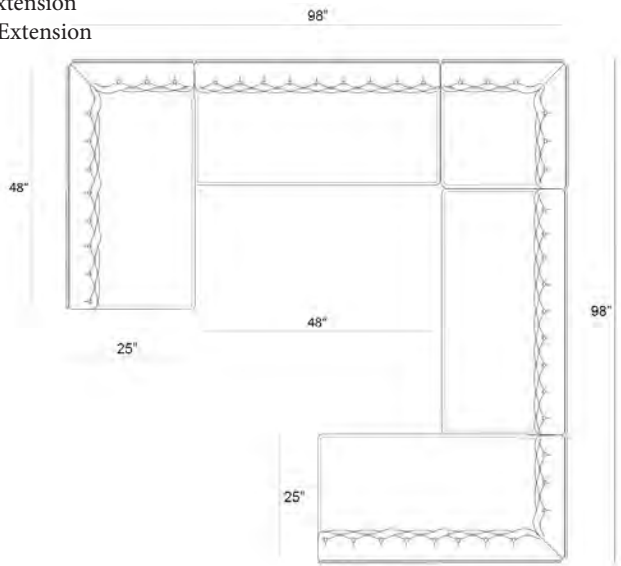



SKU: FLAT LUXURY BOOTH



PRODUCT SPECIFICATIONS

Unique design and superior comfort as you bring this FLAT LUXURY Booth on the stage in your establishment , an expressive Commercial Restaurant Furniture collection featuring Modern Design beautifully corresponding with all components such as metal, wood and upholstered elements, Polk Restaurant and lounge seating, deliver stellar form and Modern Restaurant Design not to mention a variety of options to realize a purpose beyond simply having seats in your place.

Luxurious and handmade product will give your restaurant an exclusive design with commercial grade quality. This product is available in a variety of colors. We use only commercial grade vinyls and fabrics, with abrasive resistance of 500,000 double rubs. All upholstery is CAL 117 certified and designed specifically for applications such as restaurant, hospitality, contract, health care and education. Carbon steel frame is fully welded with gunmetal powder coated finish. Handcrafted in USA.

Length: 48", 60" or 73"

Width: 27"

Height: 36"

Seating Depth: 18"

Seating Height: 22"





SKU: CHANNEL LUXURY BOOTH



PRODUCT SPECIFICATIONS

Unique design and superior comfort as you bring this CHANNEL LUXURY Booth on the stage in your establishment , an expressive Commercial Restaurant Furniture collection featuring Channel Design beautifully corresponding with all components such as metal, wood and upholstered elements, Polk Restaurant and lounge seating, deliver stellar form and Modern Restaurant Design not to mention a variety of options to realize a purpose beyond simply having seats in your place.

Luxurious and handmade product will give your restaurant an exclusive design with commercial grade quality. This product is available in a variety of colors. We use only commercial grade vinyls and fabrics, with abrasive resistance of 500,000 double rubs. All upholstery is CAL 117 certified and designed specifically for applications such as restaurant, hospitality, contract, health care and education. Carbon steel frame is fully welded with gunmetal powder coated finish. Handcrafted in USA,

Length: 48", 60" or 73"
Width: 27"
Height: 36"
Seating Depth: 18"
Seating Height: 22"





SKU: DIAMOND LUXURY BOOTH



PRODUCT SPECIFICATIONS

Unique design and superior comfort as you bring this DIAMOND LUXURY Booth on the stage in your establishment , an expressive Commercial Restaurant Furniture collection featuring Modern Design beautifully corresponding with all components such as metal, wood and upholstered elements, Polk Restaurant and lounge seating, deliver stellar form and Modern Restaurant Design not to mention a variety of options to realize a purpose beyond simply having seats in your place.

Luxurious and handmade product will give your restaurant an exclusive design with commercial grade quality. This product is available in a variety of colors. We use only commercial grade vinyls and fabrics, with abrasive resistance of 500,000 double rubs. All upholstery is CAL 117 certified and designed specifically for applications such as restaurant, hospitality, contract, health care and education. Carbon steel frame is fully welded with gunmetal powder coated finish. Handcrafted in USA.

Length: 48", 60" or 73"

Width: 27"

Height: 36"

Seating Depth: 18"

Seating Height: 22"



Privacy Side Panel - Available in 41" or 51" Height



SKU: KANSAS CITY 2



PRODUCT SPECIFICATIONS

Offering KANSAS CITY 2 Lounge and Restaurants seating with comfort and style, a generous-sized Unique Laminate table, and charging power connectivity, invites you to take a break for short term stays, or settle in for the long haul. Accommodating single users as well as Restaurant and Lounge seating for 4 people but with the flexibility to create higher capacity groupings, units can be positioned throughout open spaces to serve any number of purposes.

Featured booth seating is scaled perfectly to make the most of narrow spaces. Comfort and privacy: tall privacy wall provides a more intimate environment for your patrons. This product is available in a variety of colors. We use only commercial grade vinyls and fabrics, with abrasive resistance of 500,000 double rubs. All upholstery is CAL 117 certified and designed specifically for applications such as restaurant, hospitality, contract, health care and education. Carbon steel frame is fully welded with gunmetal powder coated finish. Optional power outlet features 2x 110v and 2x USB ports. Please note the outlet is installed at the center on top of privacy wall.

- Overall outside perimeter as pictured: 27" by 80" by 27"
- Overall Height with Side Panel: 41" or 51"
- Booth Seat: L 22" | D 22"
- Table Top: L 28" | D 28" | H 31"
- Seating Depth 22"
- Seat Height 18.5"

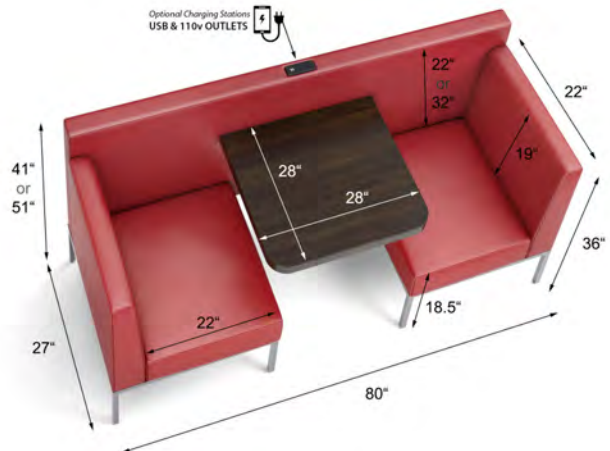

Privacy Side Panel - Available in 41" or 51" Height



SKU: KANSAS CITY BOOTH



PRODUCT SPECIFICATIONS

Offering KANSAS CITY Lounge and Restaurants seating with comfort and style, a generous-sized Unique Laminate table, and charging power connectivity, invites you to take a break for short term stays, or settle in for the long haul. Accommodating single users as well as Restaurant and Lounge seating for 4 people but with the flexibility to create higher capacity groupings, units can be positioned throughout open spaces to serve any number of purposes.

Featured booth seating is scaled perfectly to make the most of narrow spaces. Comfort and privacy: tall privacy wall provides a more intimate environment for your patrons. This product is available in a variety of colors. We use only commercial grade vinyls and fabrics, with abrasive resistance of 500,000 double rubs. All upholstery is CAL 117 certified and designed specifically for applications such as restaurant, hospitality, contract, health care and education. Carbon steel frame is fully welded with gunmetal powder coated finish. Optional power outlet features 2x 110v and 2x USB ports. Please note the outlet is installed at the center on top of privacy wall.

Overall outside perimeter as pictured: 27" by 80" by 27"
 Overall Height with Side Panel: 41" or 51"
 Booth Seat: L 22" | D 22"
 Table Top: L 28" | D 28" | H 31"
 Seating Depth 22"
 Seat Height 18.5"

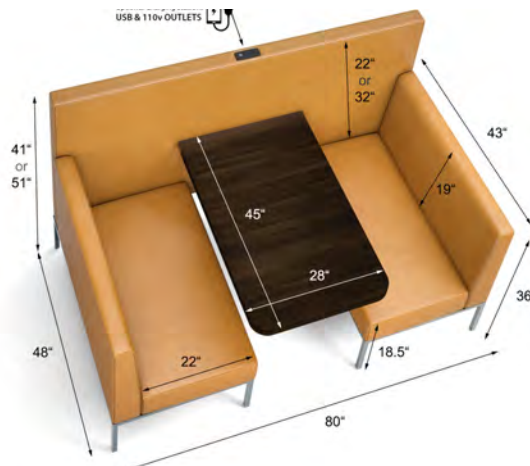
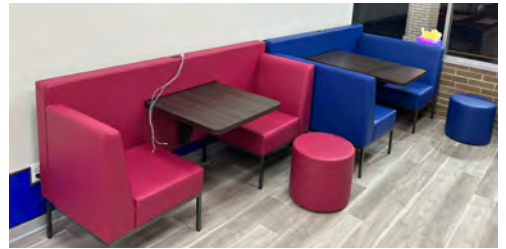



SKU: TEXAS BOOTH



PRODUCT SPECIFICATIONS

TEXAS Booth is one of the most detailed and labor-intensive models we manufacture — and one of the most visually impressive. It is premium, high-detail models as a Top Back panel Head-Roll support with diamond tufting, solid wood construction frame, and performance upholstery built for commercial use. This booth delivers timeless luxury and commercial-grade performance in any restaurant, lounge, or VIP space.

Constructed with high-quality materials and expert craftsmanship, this booth is built to withstand the rigors of daily use in bustling hospitality environments. Upholstered banquette seating with deep soft cushioned padding for the most comfort and support. Frame is made from solid wood. Cushions are made of high density CAL 117 certified foam. Super high-performance commercial grade vinyl featuring 500,000 double rubs, California and Boston fire codes certifications. Common applications in hospitality, healthcare, contract, education, marine and automotive industries.

Length 48" or 60"
Width: 24"
Height 42"
Seating Depth 18"
Seating Height 18"



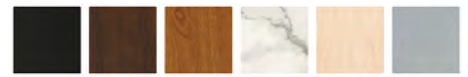

SKU: ALEXANDRIA BOOTH

PRODUCT SPECIFICATIONS

A perfect compact U-shape seating with comfort and style, a generous-sized Unique Laminate table, and charging power connectivity. The special COMPACT design provides restaurant seating for 4 people but with the flexibility to create higher capacity groupings, units can be positioned throughout open spaces back to back or set against the wall to serve any number of purposes.

Featured booth seating is scaled perfectly to make the most of narrow spaces. Comfort and privacy: tall privacy wall provides a more intimate environment for your patrons. This product is available in a variety of colors. We use only commercial grade vinyls and fabrics, with abrasive resistance of 500,000 double rubs. All upholstery is CAL 117 certified and designed specifically for applications such as restaurant, hospitality, contract, health care and education. Featuring a laminated finish, this table is thoroughly protected from heat, moisture and scratches. Optional power outlet features 2x 110v and 2x USB ports.

Overall outside perimeter as pictured: 48" by 72" by 48"
 Overall Height with Side Panel: 42"
 Booth Seat: L 42" | D 18"
 Table Top: L 45" | D 30" | H 30.5"
 Seating Depth 18"
 Seat Height 18"

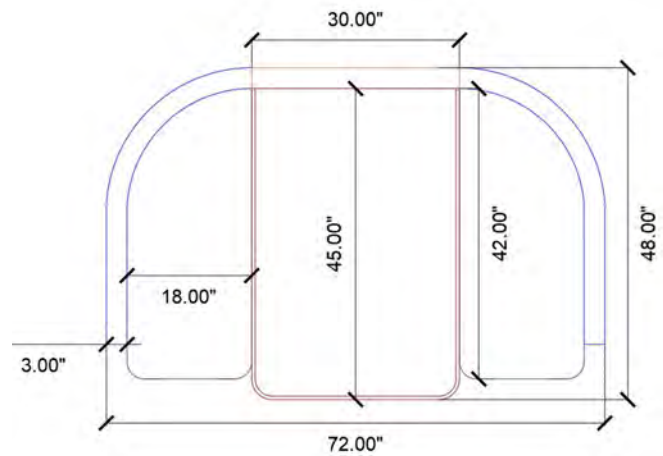
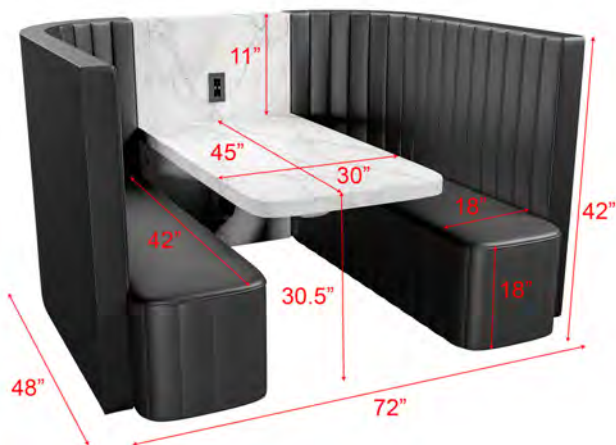



SKU: MONTANA DOUBLE BOOTH



PRODUCT SPECIFICATIONS

Thoughtfully designed for the modern collaborative gathering, private conversation, or simply dining experience, this ALEXANDRIA Booth sets the tone for unique and luxury restaurant décor. With the intimacy of having a family dinner to the sophistication of creating a VIP seating ALEXANDRIA will give your establishment a Modern and practical look of dynamic era of open space engagement.

Luxurious and handmade product will give your restaurant an exclusive design with commercial grade quality. This product is available in a variety of colors. We use only commercial grade vinyls and fabrics, with abrasive resistance of 500,000 double rubs. All upholstery is CAL 117 certified and designed specifically for applications such as restaurant, hospitality, contract, health care and education.

Premium Formica® frames finishes are thoroughly protected from heat, moisture and scratches. The 20" seating surface of this model is designed to fit any space while offering you and your guests maximum comfort. Handcrafted in USA.

Length: 60"

Width: 26"

Height: 48"

Seating Depth: 20"

Seating Height: 19.5"



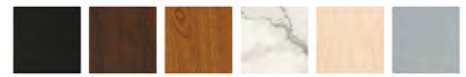

SKU: OKLAHOMA BOOTH



PRODUCT SPECIFICATIONS

Thoughtfully designed for the modern collaborative gathering, private conversation, or simply dining experience, this OKLAHOMA Booth sets the tone for unique and luxury restaurant décor. With the intimacy of having a family dinner to the sophistication of creating a VIP seating OKLAHOMA will give your establishment a Modern and practical look of dynamic era of open space engagement.

Luxurious and handmade product will give your restaurant an exclusive design with commercial grade quality. We use only commercial grade vinyls and fabrics, with abrasive resistance of 500,000 double rubs. All upholstery is CAL 117 certified and designed specifically for applications such as restaurant, hospitality, contract, health care and education. Featuring a laminated finish, this table is thoroughly protected from heat, moisture and scratches. Footrest features a super-durable silver panel for feet support.

Custom Upholstery and Frame Finishes are available. Please contact us.

- Length 60"
- Depth 26"
- Height 60"
- Seating Depth 20"
- Seating Height 31.5"



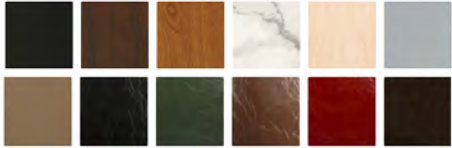

SKU: TIARA BOOTH



PRODUCT SPECIFICATIONS

This TIARA booth offers wide seating space and flexibility of dining experience for your restaurant guest. It's designed to meet commercial grade and flammability requirements with wood frames and Laminate finishes. We do offer high quality upholstered vinyl back and seats. Extra stability is provided with four American made steel leg bases.

Featured booth seating is scaled perfectly to make the most of narrow spaces. Comfort and privacy: tall privacy wall provides a more intimate environment for your patrons. This product is available in a variety of colors. We use only commercial grade vinyls and fabrics, with abrasive resistance of 500,000 double rubs. All upholstery is CAL 117 certified and designed specifically for applications such as restaurant, hospitality, contract, health care and education. Featuring a laminated finish, this table is thoroughly protected from heat, moisture and scratches. 4" metal black powder coated heavy-duty legs. Optional power outlet features 2x 110v and 2x USB ports.

- Length 65"
- Depth Single Booth 26" | Depth Double Booth 52"
- Height 46"
- Seating Depth 21"
- Seating Height 19.5"
- Featured back panels are only available in Black. Seat can be customized.



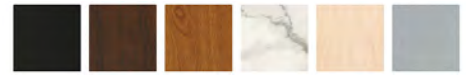

SKU: QUEEN BOOTH

PRODUCT SPECIFICATIONS

This QUEEN booth delivers durability, comfort, and style all in one sleek package. Featuring dual black button-tufted panels, this model restaurant booth adds timeless sophistication to any restaurant setting. Built with a solid plywood frame and fully reinforced with bolts and screws, each seat is designed to support up to 400 lbs — making it ideal for high-traffic hospitality venues. Available as a 2- or 3-seater, the booth can be customized with optional laminate finishes to match your restaurant's interior. The clean lines and sharp contrast between the tufted upholstery and maple frame bring a polished, upscale look to dining spaces. For added functionality, you can include built-in charging stations — perfect for today's tech-connected guests. Whether you're designing a casual café or an upscale lounge, this USA-made booth offers unmatched quality and versatility.

This product is available in a variety of colors. We use only commercial grade vinyls and fabrics, with abrasive resistance of 500,000 double rubs. All upholstery is CAL 117 certified and designed specifically for applications such as restaurant, hospitality, contract, health care and education. Featuring a laminated finish, this table is thoroughly protected from heat, moisture and scratches. 4".

Length 48" or 65"

Width 23" (Single) | 45" (Double)

Height 48"

Seating Depth 19"

Seating Height 18.5"

Seat cushion: 4.5"

Featured back panels are only available in Black. Seat can be customized.



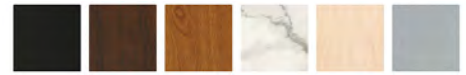

SKU: KING BOOTH

PRODUCT SPECIFICATIONS

Bar height booths foster a more engaging and dynamic dining experience. The elevated seating position encourages a casual, relaxed ambiance, making it easier for guests to interact and enjoy each other's company. This social atmosphere is particularly appealing for gatherings, celebrations, and lively dining experiences. Bar height booths are an excellent solution for maximizing space efficiency in restaurants. Their elevated design allows for better utilization of vertical space, often accommodating more seating without compromising comfort. This is especially beneficial in smaller or crowded dining areas where space is at a premium. Available in various configurations such as banquette, L-shape, or U-shape, bar height booths offer versatile seating arrangements to suit different restaurant layouts and customer needs.

This product is available in a variety of colors. We use only commercial grade vinyls and fabrics, with abrasive resistance of 500,000 double rubs. All upholstery is CAL 117 certified and designed specifically for applications such as restaurant, hospitality, contract, health care and education. Featuring a laminated finish, this table is thoroughly protected from heat, moisture and scratches. Footrest features a super-durable black starboard panel for feet support.

- Length (side to side) 48"
- Height (floor to top) 45"
- Height Step (floor to step) 12"
- Overall Depth 27"
- Seating Depth 18"
- Seating Height (from step to seat top) 19"



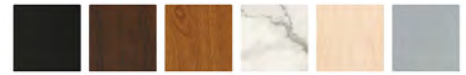

SKU: ELEVATED BOOTH



PRODUCT SPECIFICATIONS

Bar height booths foster a more engaging and dynamic dining experience. The elevated seating position encourages a casual, relaxed ambiance, making it easier for guests to interact and enjoy each other's company. This social atmosphere is particularly appealing for gatherings, celebrations, and lively dining experiences. Bar height booths are an excellent solution for maximizing space efficiency in restaurants. Their elevated design allows for better utilization of vertical space, often accommodating more seating without compromising comfort. This is especially beneficial in smaller or crowded dining areas where space is at a premium.

The premium Formica base wrap around the back and base creates a beautiful and luxurious look. Laminate features fire resistance Stain, scratch and impact resistant under normal use conditions. We use only commercial grade vinyls and fabrics, with abrasive resistance of 500,000 double rubs. All upholstery is CAL 117 certified and designed specifically for applications such as restaurant, hospitality, contract, health care and education. Featuring a laminated finish, this table is thoroughly protected from heat, moisture and scratches. Footrest features a super-durable silver panel for feet support.

- Length (side to side) 48"
- Height (floor to top) 60"
- Height Step (floor to step) 12"
- Overall Depth 36"
- Seating Depth 19"
- Seating Height (from step to seat top) 19"



Flat



Channel Tufted



Button Tufted





SKU: HF-17DC



PRODUCT SPECIFICATIONS

This stylish restaurant chair combines a modern aesthetic with exceptional durability. Featuring a diamond-tufted back and upholstered in high-performance commercial-grade vinyl, it offers both elegance and comfort. The chair is built to withstand up to 350 lbs, making it ideal for high-traffic use and ensuring lasting reliability. Applications: Ideal for upscale restaurants, cafes, and bistros, this chair complements modern interiors with its stylish design. Its robust build makes it perfect for high-traffic venues such as hotel dining areas, banquet halls, and corporate meeting spaces. The vibrant upholstery and sleek legs also make it an excellent choice for boutique lounges or trendy eateries aiming to create a bold statement. Available with Black or Gold legs.

Width: 23"
Depth: 24"
Height: 35"
Seating Height: 17.5"
Seat: 22" x 18" x 4"
Weight: 19 lbs





SKU: HF-17BS



PRODUCT SPECIFICATIONS

The HF-17BS Swivel Designer Bar Stool delivers the perfect balance of comfort, style, and commercial-grade performance, making it a top seller across multiple industries. From airports and restaurants to golf simulators, bowling centers, and entertainment venues, this model adapts effortlessly to any environment. The smooth swivel seat and supportive backrest provide exceptional comfort, while the diamond-tufted outer back adds a refined, upscale look. With endless upholstery options, every business can customize the 4017 to match its own design vision. Built on a fully welded metal frame with an impressive 450 lb weight capacity, this stool ensures long-term durability and reliability.

- Width: 23"
- Depth: 22"
- Height: 44"
- Seating Height: 31"
- Seat: 22" x 18" x 4"
- Weight: 30 lbs

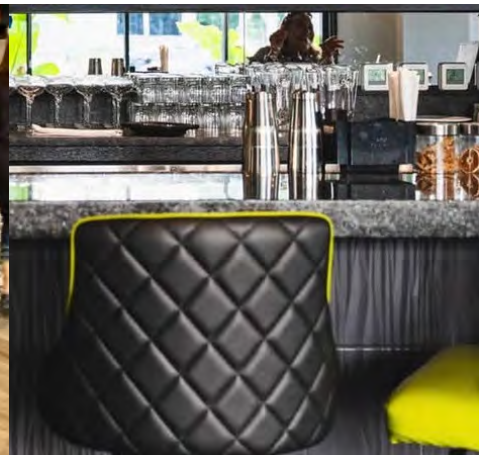



SKU: HF-18DC



PRODUCT SPECIFICATIONS

This stylish restaurant chair combines a modern aesthetic with exceptional durability. Featuring a channel-tufted back and upholstered in high-performance commercial-grade vinyl, it offers both elegance and comfort. The chair is built to withstand up to 350 lbs, making it ideal for high-traffic use and ensuring lasting reliability. Applications: Ideal for upscale restaurants, cafes, and bistros, this chair complements modern interiors with its stylish design. Its robust build makes it perfect for high-traffic venues such as hotel dining areas, banquet halls, and corporate meeting spaces. The vibrant upholstery and sleek legs also make it an excellent choice for boutique lounges or trendy eateries aiming to create a bold statement. Available with Black or Gold legs.

Width: 23"
Depth: 24"
Height: 35"
Seating Height: 17.5"
Seat: 22" W x 18" D
Weight: 19lbs





SKU: HF-18BS



PRODUCT SPECIFICATIONS

The HF-18BS Swivel Designer Bar Stool delivers the perfect balance of comfort, style, and commercial-grade performance, making it a top seller across multiple industries. From airports and restaurants to golf simulators, bowling centers, and entertainment venues, this model adapts effortlessly to any environment. The smooth swivel seat and supportive backrest provide exceptional comfort, while the Channel outer back adds a refined, upscale look. With endless upholstery options, every business can customize the HF-18BS to match its own design vision. Built on a fully welded metal frame with an impressive 450 lb weight capacity, this stool ensures long-term durability and reliability. Model 4018 is a proven favorite for operators who want style that performs and quality that lasts.

Width: 23"

Depth: 22"

Height: 44"

Seating Height: 31"

Seat: 22" x 18" x 4"

Weight: 30 lbs





SKU: HF-19DC



PRODUCT SPECIFICATIONS

Bold, stylish, and handcrafted in the USA, this modern dining chair is where high fashion meets commercial durability. Featuring a solid wood core, luxurious two-tone upholstery, and sleek gold metal legs, it's built to impress in any upscale restaurant, lounge, or hospitality space. The vertically channeled backrest adds texture and dimension, while the ergonomic silhouette ensures comfort during extended seating. Customizable in any fabric, vinyl, or finish, this model transforms color into character. Whether you're designing a vibrant dining room or a bold VIP space, this chair delivers maximum visual impact with unmatched craftsmanship.

Available with Black or Gold legs.

- Width: 22"
- Depth: 23"
- Height: 35"
- Seating Height: 17.5"
- Seat: 22" x 18" x 4"
- Weight: 18 lbs





SKU: HF-19BS



PRODUCT SPECIFICATIONS

The HF-19BS Swivel Designer Bar Stool delivers the perfect balance of comfort, style, and commercial-grade performance, making it a top seller across multiple industries. From airports and restaurants to golf simulators, bowling centers, and entertainment venues, this model adapts effortlessly to any environment. The smooth swivel seat and supportive backrest provide exceptional comfort, while the Channel and Diamond outer back in combination adds a refined, upscale look. With endless upholstery options, every business can customize the HF-19BS to match its own design vision. Built on a fully welded metal frame with an impressive 450 lb weight capacity, this stool ensures long-term durability and reliability. Model HF-19BS is a proven favorite for operators who want style that performs and quality that lasts.

Width: 22.5"

Depth: 22"

Height: 44"

Seating Height: 31"

Seating Depth: 21.5"

Seating Areal 18" x 21.5"





SKU: HF-04DC



PRODUCT SPECIFICATIONS

The HF-04DC Restaurant Chair is where modern luxury meets performance. Designed to make a visual impact the instant guests walk in, this chair features a distinctive curved radius back that gracefully wraps around the body, offering support, comfort, and a premium lounge-like feel. The detailing is a showpiece on its own—hand-crafted diamond stitching, optional button tufting, and beautifully tailored upholstery that reflects true craftsmanship. Ideal for upscale restaurants, lounges, steakhouses, and contemporary dining spaces, Model HF-04DC combines elegance with structural reliability. Each chair has been weight-tested for 350 lbs (typo corrected from your note if needed) and is built to withstand the demands of daily commercial use. Upholstery options range from high-performance vinyl to fabric in single-tone or two-tone combinations, allowing every venue to design its own unique statement.

Width: 24”
 Depth: 22”
 Height: 26”
 Seating Height: 17.5”
 Seat: 22.5” x 19” x 4”
 Weight: 20lbs





SKU: HF-04BS



PRODUCT SPECIFICATIONS

The Luxury Bar Stool Model HF-04BS is designed for operators who want their space to stand out far above the competition. Featuring a tall backrest, curved arms, and elegant diamond-tufted stitching, this bar stool delivers a high-end aesthetic that instantly elevates any bar, lounge, nightclub, or restaurant. The square seat, paired with a smooth 360° commercial swivel base, provides both comfort and functionality for busy hospitality environments. Upholstered in premium two-tone, high-performance materials, Model HF-04BS is built to handle heavy traffic while maintaining its sophisticated appearance. As shown in the real client installation images below, this model continues to impress customers who seek style, durability, and a true luxury seating experience.

Width: 25"
Depth: 22"
Height: 40"
Seating Height: 31"
Seat: 22.5" x 19" x 4"
Weight: 31 lbs

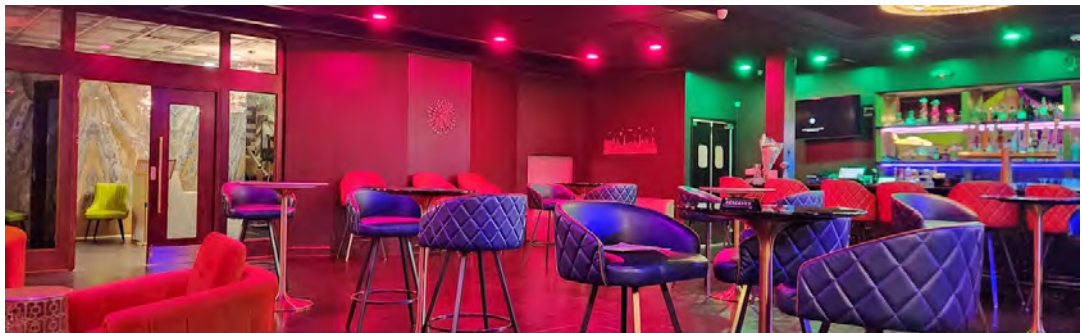



SKU: HF-32DC



PRODUCT SPECIFICATIONS

This exclusive designer collection restaurant chair is where comfort meets craftsmanship. The fully wrapped frame offers ergonomic support, embracing the body for a comfortable dining experience. Its diamond-stitched outer back mirrors the design of matching restaurant booths, creating a cohesive, high-end look throughout your space. With a 350+ lb weight capacity, this restaurant chair is as sturdy as it is striking. The sculpted lines and stitching details create a standout focal point in any restaurant or lounge. Available leg finishes: Gold, Black, or Steel.

Width: 23.5"

Depth: 22"

Height: 31"

Seating Height: 17.5"

Seat: 22.5" W x 19" D

Weight: 20 lbs

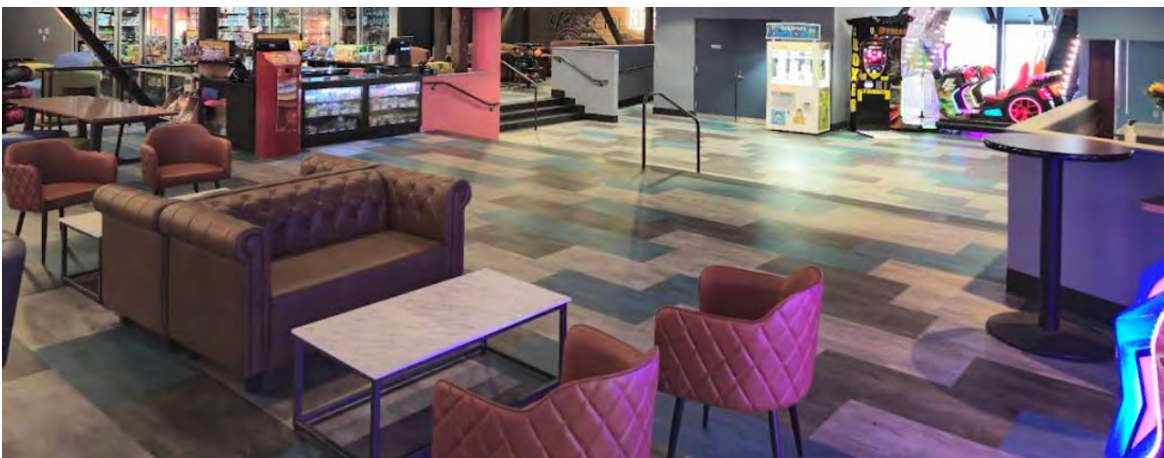



SKU: HF-88DC



PRODUCT SPECIFICATIONS

The HF-88DC Chair is a true standout in any setting which brings upscale design to restaurants, lounges, and hospitality spaces. Its sculpted curved back features a CNC-routed cutout for visual depth and comfort, while the contrast piping outlines the silhouette — creating a bold, geometric focal point that finishes the look. The final detail of the wrap-around piping cord completes the curved looks with every line all around this Unique Restaurant and Hospitality Chair.

Built on a solid wood frame with black or gold metal legs, this chair is commercial-grade with a 350 lb+ weight capacity. Upholstered in our new Kelton vinyl, the surface mimics genuine hide with incredible realism and durability.

Width: 23"
Depth: 23"
Height: 30"
Seating Height: 17.5"
Seat: 20" x 19" x 3"
Weight: 23 lbs





SKU: FAME



PRODUCT SPECIFICATIONS

Elevate your seating experience with this custom-crafted chair, blending contemporary elegance with unmatched durability. The sleek modern design features gracefully curved upholstered seating, offering a soft and inviting feel, paired with elegant seaboard waterproof frame that provide a striking visual contrast. Its exquisite two-tone upholstery options and clean lines make it a stylish addition to any space.

With its smooth contours and a timeless blend of form and function, this chair is a versatile choice for modern interiors such as Hotels, Cruise Ships, Medical and Government facilities.

Width: 24"
Depth: 21"
Height: 31"
Seat Height: 17.5"
Seat: 22" x 19" x 3"
Weight: 23lbs





SKU: HF-38DC



PRODUCT SPECIFICATIONS

Premium Channel-Back Dining Chair | Comfort Built for Steakhouses & Upscale Venues. The HF-38DC is designed for restaurants where com-fort equals revenue. If your goal is to surprise your guests, keep them seated longer, and elevate their dining experience, this model delivers. Thick cushioning, a supportive channel-tufted back, and beautifully contoured upholstery create an inviting feel that steakhouses, fine-dining rooms, and luxury lounges love. Built with commercial-grade structure and premium upholstery, DC1838 doesn't just look elegant — it per-forms. Its modern silhouette pairs with metal legs for strength and longevity, ensuring stability through years of high-traffic use. The comfort encourages guests to settle in, enjoy another drink, and stay a little longer, making this chair as profitable as it is beautiful. When you want seating that stands out, feels extraordinary, and complements a premium menu — HF-38DC is the ask-no-questions option. Two-Tone Modern Lounge / Dining Chair – Barrel-Back Comfort & Style

Width: 24.5"

Depth: 22"

Height: 31"

Seat Height: 18"

Seat: 22"x 18" x 3"

Weight: 20 lbs





SKU: HF-38BS



PRODUCT SPECIFICATIONS

Built to be sturdy, pieces can be transported with ease and used in high traffic areas.

Upholstered banquette seating with deep soft cushioned padding for the most comfort and support

Frame is made from solid wood. Cushions are made of high density CAL 117 certified foam. Super high-performance commercial grade vinyl featuring 500,000 double rubs, California and Boston fire codes certifications. Common applications in hospitality, healthcare, contract, education, marine and automotive industries.

Width: 22.5"

Depth: 23"

Height: 45"

Seating Height: 30.5"

Seat 18" x 19"





SKU: HF-38DC



PRODUCT SPECIFICATIONS

The HF-38DC chair is a modern masterpiece defined by its sculpted, wave-like curves that gracefully shape around the body. The fluid arms and backrest create a continuous silhouette that not only catches the eye but also offers natural ergonomic support. Upholstered in high-performance fabric and set on strong, fully reinforced wood frame and metal legs, this chair is built for the demands of commercial use with 350LB weight capacity. Ideal for restaurants, lounges, and hospitality spaces looking to make a statement, the HF-38DC adds both comfort and character. Custom upholstery options allow you to tailor the look to your design vision. Made in USA

Width: 25"

Depth: 24"

Height: 30"

Seating Height: 17.5"

Seat: 23" x 20.5" x 3"

Weight: 16lbs



SKU: HF82-DTF



PRODUCT SPECIFICATIONS

Introducing our new metal Restaurant chair HF82-DTF collection—built from the ground up for strength, style, and commercial performance. Crafted in the USA, each chair starts with a fully welded, one-piece powder-coated metal frame—no screws, bolts, or weak joints. This design delivers unmatched durability with a weight capacity exceeding 400 lbs, making it ideal for high-traffic restaurants, bars, and hospitality venues. The HF82-DTF chair features a bold diamond-tufted back and plush seat, combining luxury with industrial-grade strength. At our factory, we customize each piece with premium upholstery, offering endless combinations to suit your design vision. These chairs are not just assembled—they're engineered to last. Whether you're designing a modern dining area or a rustic lounge, this series delivers reliability, comfort, and visual impact that stands out and holds up.

Width: 18"
Depth: 21"
Height: 40.5"
Seat Height: 19"
Seat: 18" W x 17" D
Weight: 21lbs





SKU: HF-82BSTF



PRODUCT SPECIFICATIONS

The HF-82BSTF Bar Stool is one of the most preferred seating choices among today's high-end bars, lounges, and upscale pubs serving top-dollar cock-tails and crafted beverages. Built on a fully welded, heavy-duty gunmetal frame, this model offers unmatched durability and an impressive 450 lb weight capacity, ensuring long-term performance in the busiest environments. Wrapped in premium glazed upholstery, the seat and back feature elegant diamond-tufted stitching that delivers both luxury and visual impact. Its refined silhouette, sturdy construction, and attention to detail make the 782 a true state-of-the-art bar stool designed to elevate any interior. For operators seeking dependable strength paired with upscale design, this stool stands out as a timeless, reliable favorite.

Width: 17"
Depth: 21.5"
Height: 43"
Seat Height: 31"
Seat Depth: 17"

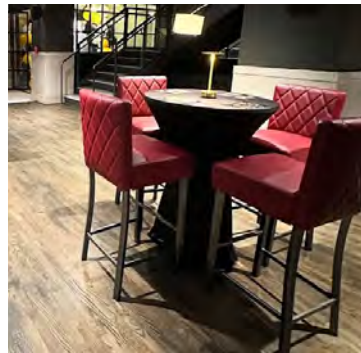



SKU: HF-DC2TONE



PRODUCT SPECIFICATIONS

Introducing our new metal Restaurant chair HF-DC2TONE collection—built from the ground up for strength, style, and commercial performance. Crafted in the USA, each chair starts with a fully welded, one-piece powder-coated metal frame—no screws, bolts, or weak joints. This design delivers unmatched durability with a weight capacity exceeding 400 lbs, making it ideal for high-traffic restaurants, bars, and hospitality venues. The HF-DC2TONE Restaurant Chair features a bold two-tone design and plush seat, combining luxury with industrial-grade strength. At our factory, we customize each piece with premium upholstery, offering endless combinations to suit your design vision. These chairs are not just assembled—they're engineered to last. Whether you're designing a modern dining area or a rustic lounge, this series delivers reliability, comfort, and visual impact that stands out and holds up.

Width: 18"

Depth: 21"

Height: 35.5"

Seat Height: 19"

Seat: 18" x 17" x 5"

Weight: 20lbs



SKU: HF - BS2TONE



PRODUCT SPECIFICATIONS

Introducing our new metal Bar stool HF - BS2TONE collection—built from the ground up for strength, style, and commercial performance. Crafted in the USA, each chair starts with a fully welded, one-piece powder-coated metal frame—no screws, bolts, or weak joints. This design delivers unmatched durability with a weight capacity exceeding 400 lbs, making it ideal for high-traffic restaurants, bars, and hospitality venues. The HF - BS2TONE Bar Stool features a bold design and plush seat, combining luxury with industrial-grade strength. At our factory, we customize each piece with premium upholstery, offering endless combinations to suit your design vision. These chairs are not just assembled—they're engineered to last. Whether you're designing a modern dining area or a rustic lounge, this series delivers reliability, comfort, and visual impact that stands out and holds up.

Width: 17"

Depth: 21.5"

Height: 43"

Seat Height: 31"

Seat Depth: 17"





SKU: HF-82MD



PRODUCT SPECIFICATIONS

Introducing our new metal Restaurant chair 782 collection—built from the ground up for strength, style, and commercial performance. Crafted in the USA, each chair starts with a fully welded, one-piece powder-coated metal frame—no screws, bolts, or weak joints. This design delivers unmatched durability with a weight capacity exceeding 400 lbs, making it ideal for high-traffic restaurants, bars, and hospitality venues. The HF-82MD Bar Stool features a bold diamond-tufted back and plush seat, combining luxury with industrial-grade strength. At our factory, we customize each piece with premium upholstery, offering endless combinations to suit your design vision. These chairs are not just assembled—they're engineered to last. Whether you're designing a modern dining area or a rustic lounge, this series delivers reliability, comfort, and visual impact that stands out and holds up.

Width: 18"

Depth: 21"

Height: 40.5"

Seat Height: 19"

Seat: 18" W x 17" D

Weight: 21lbs



SKU: HF-82DCMD



PRODUCT SPECIFICATIONS

The HF-82DCMD Bar Stool (Flat-Back Diamond Upholstery Version) remains a top pick for upscale bars, lounges, and premium pubs serving high-end drinks. Built on a fully welded, heavy-duty gunmetal frame, this stool boasts a robust 450 lb weight capacity, delivering reliability and durability in high-traffic venues. The flat back gives a sleek, modern silhouette, while the premium glazed upholstery and diamond-tufted stitching add a luxurious, eye-catching detail. Combining classic craftsmanship with contemporary design, the stool offers both comfort and visual appeal. For those seeking a sophisticated seating solution that blends strength, style, and timeless elegance, this model delivers every time.

Width: 17"
Depth: 21.5"
Height: 43"
Seat Height: 31"
Seat Depth: 17"





SKU: HF-90DC



PRODUCT SPECIFICATIONS

Model HF-90DC features a clean, architectural frame paired with a fully padded square backrest for enhanced comfort and visual balance. Its boxy silhouette and premium cushioning offer a sophisticated yet practical seating solution for restaurants, cafés, and public venues.

Upholstered in commercial-grade vinyl and supported by a fully welded gunmetal steel frame, this chair is built to last—and rated to hold up to 350 lbs. The extra-cushioned back panel sets it apart, delivering a noticeably softer experience for guests. Made in the USA and available in a variety of finishes and colors to match any interior aesthetic.

Width: 17"
Depth: 19"
Height: 32"
Seat Height: 19"
Seat: 17.5" x 16" x 2"
Weight: 17lbs

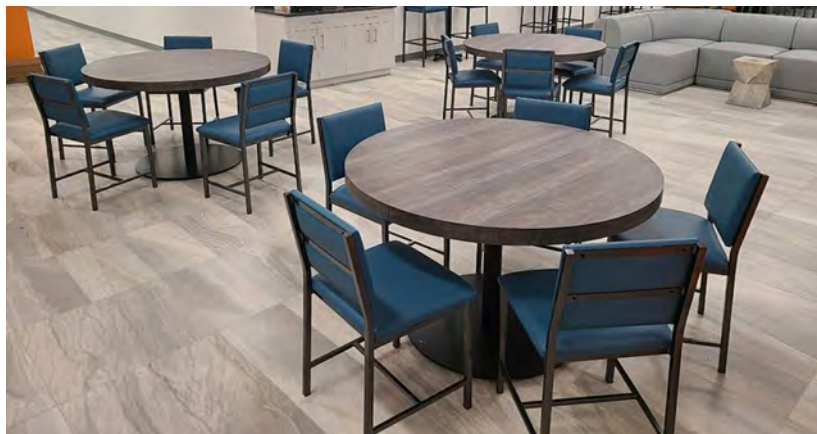



SKU: HF-90BS



PRODUCT SPECIFICATIONS

Model HF-90BS features a clean, architectural frame paired with a fully padded square backrest for enhanced comfort and visual balance. Its boxy silhouette and premium cushioning offer a sophisticated yet practical seating solution for restaurants, cafés, and public venues. Upholstered in commercial-grade vinyl and supported by a fully welded gunmetal steel frame, this chair is built to last—and rated to hold up to 350 lbs. Made in the USA and available in a variety of finishes and colors to match any interior aesthetic.

Width: 19.5"
Depth: 19"
Height: 41"
Seat Height: 31"
Seat: 19" x 15" x 2"
Weight: 21 lbs





SKU: HF-97DC



PRODUCT SPECIFICATIONS

Model HF-97DC delivers a refined industrial look with its signature gunmetal tubular frame, uniquely wrapping around the backrest and seat cushion for full structural support and visual impact. The rounded frame not only reinforces stability but creates a bold, continuous form that feels modern and inviting. Upholstered in commercial-grade materials, this chair is engineered for everyday use in busy restaurants, cafés, and social venues. The fully welded base and rounded pedestal provide exceptional balance and durability. Proudly crafted in the USA, the HF-97DC offers design-forward seating that blends strong geometry with plush comfort and lasting performance.

Width: 17"
Depth: 20"
Height: 41"
Seat Height: 30.5"
Seat: 17" x 16" x 2"
Weight: 22 lbs





SKU: HF-97BS



PRODUCT SPECIFICATIONS

This model Bar stool delivers a clean, modern industrial aesthetic with its fully welded construction and signature radius-tubing frame. Built for demanding commercial environments, this stool offers a 350 lb weight capacity and a heavy-duty gunmetal tubular round base, ensuring long-lasting performance in restaurants, cafés, breweries, food halls, and architectural-style spaces. Designers love this model for its sleek lines and durable structure, often selecting it for industrial buildings and hospitality venues seeking a bold, contemporary look. The seat can be upholstered in any color, with the option to create a striking two-tone combination for a more customized visual impact. Crafted with commercial-grade materials and professional craftsmanship, Model HF-97BS provides both style and stability—making it an excellent choice for high-traffic facilities.

Width: 17"

Depth: 20"

Height: 41"

Seat Height: 30.5"

Seat: 17" x 16" x 2"

Weight: 22 lbs





SKU: HF-44



PRODUCT SPECIFICATIONS

This stackable restaurant chair offers the perfect balance of durability, comfort, and space-saving design. Built on a fully welded gunmetal steel frame, the chair delivers long-lasting commercial performance, making it ideal for restaurants, cafés, food courts, banquet halls, and high-traffic venues. Its clean, modern silhouette pairs with a padded commercial-grade vinyl seat and back, ensuring comfort while maintaining easy wipe-down maintenance. The stackable structure allows multiple chairs to be stored quickly and efficiently, helping operators manage floor space, cleaning, and event setups with ease. Despite its slim profile, the frame provides excellent stability and support for everyday use. Strong, practical, and modern — this stackable gunmetal chair is built for real hospitality environments where flexibility and durability matter most.

Width: 18"
Depth: 24"
Height: 34"
Seat Height: 18"



SKU: HF-55



PRODUCT SPECIFICATIONS

The Model HF-55 bar stool offers a clean, modern look with the added comfort of fully padded cushions on both the seat and back. Its slightly angled backrest provides improved support, making this model an excellent choice for restaurants, bars, cafés, and hospitality venues that prioritize guest comfort during longer stays. The fully welded gunmetal frame ensures long-term stability, even in demanding commercial set-tings. A signature feature of Model HF-55 is its convenient T-shape footrest, designed to make climbing in and out of the stool easy for patrons of all ages. Upholstery is available in a wide range of commercial-grade vinyl colors, allowing operators to coordinate with any interior style. Durable, supportive, and stylish—this bar stool performs exceptionally well in high-traffic environments.

Width: 18"
Depth: 21"
Height: 41"
Seat Height: 30"





SKU: HF-41DC



PRODUCT SPECIFICATIONS

This model is fully welded and finished with a UV-resistant powder coating, making it exceptionally durable for outdoor use. Built to withstand sun, rain, humidity, and temperature changes, the frame will not weaken or corrode — perfect for patios, rooftops, waterfront restaurants, and resort settings. The seat and back are made from Starboard/Seaboard marine-grade material, the same waterproof composite used on yachts, boat consoles, and other high-exposure marine applications. This premium material will never get hot, never absorb water, and never rot, warp, or delaminate, even under constant outdoor conditions. Comfortable, maintenance-free, and engineered for long-term performance, this chair offers a modern aesthetic with the durability needed for high-traffic exterior environments. A true outdoor seating solution built to last.

Width: 21”

Depth: 24”

Height: 34”

Seat Height: 18”





SKU: HF -51BSAC



PRODUCT SPECIFICATIONS

The Model HF -51BSAC with Arms enhances the original Model HF -51BSAC by adding fully welded armrests that make it easier for patrons to pull their entire body up and get down from the stool with added stability. Designed for high-traffic hospitality use, this modern bar stool provides a strong 350 lb weight capacity, ensuring long-term performance in restaurants, bars, cafés, lounges, and hotels. Both the seat and back are fully padded with commercial-grade cushions, paired with a slightly angled backrest for superior comfort. Upholstery can be specified in any single color or a striking 2-tone combination, giving operators complete design flexibility. Built with a durable gunmetal steel frame and integrated footrest, this model offers a premium seating experience that is stylish, supportive, and built to last.

Width: 21"
Depth: 24"
Height: 34"
Seat Height: 18"



SKU: HF-12DC



PRODUCT SPECIFICATIONS

This X-Back metal chair—commonly known as the “Cross-back Chair”—delivers a timeless design with a modern industrial twist. Its clean, geometric lines and brushed gunmetal finish offer a versatile look that fits effortlessly into restaurants, cafés, and hospitality venues from coast to coast. The solid frame supports up to 350 lbs, and the cushioned commercial-grade vinyl seat adds long-term comfort in high-traffic settings. Whether it’s a trendy NYC eatery or a rustic lodge in the Midwest, this chair blends tradition with simplicity. Sometimes, less truly is more—and the enduring popularity of this model proves exactly that.

Width: 17”
Depth: 18”
Height: 34.5”
Seating Size: 17”W x 16”D
Seat Height: 18”
Weight: 13 lbs





SKU: HF-12BS



PRODUCT SPECIFICATIONS

This X-Back metal bar stool — commonly known as the “Cross-back Chair”—delivers a timeless design with a modern industrial twist. Its clean, geometric lines and brushed gunmetal finish offer a versatile look that fits effortlessly into restaurants, cafés, and hospitality venues from coast to coast. The solid frame supports up to 350 lbs, and the cushioned commercial-grade vinyl seat adds long-term comfort in high-traffic settings. Whether it’s a trendy NYC eatery or a rustic lodge in the Midwest, this bar stools blends tradition with simplicity. Sometimes, less truly is more—and the enduring popularity of this model proves exactly that.

Width: 17”
Depth: 20”
Height: 41.5”
Seating Size: 17”W x 16”D
Seat Height: 30.5”
Weight: 14.5 lbs





SKU: HF-77DC



PRODUCT SPECIFICATIONS

This stackable chair features a clean, horizontal ladder-back design and a sturdy metal frame, the perfect seating solution for high-turnover environments like fast food chains, airport dining areas, and busy food courts. The ladder back gives a modern yet timeless look, while the padded, commercial-grade vinyl seat offers comfort for guests even during quick meals. Because the chair stacks easily and securely, it saves space and allows staff to quickly clear, rearrange, or store seating as needed — especially useful for venues with fluctuating traffic. Durable, easy to clean, and built for heavy use, this model combines practicality with a sleek, casual-dining aesthetic. Fast-paced hospitality spaces love its balance of comfort, durability, and convenience.

Width: 18"
Depth: 21"
Height: 36.5"
Seat Height: 18.5"
Seat: 17.75" x 16.75" x 2"
Weight: 17 lbs





SKU: HF-71BS



PRODUCT SPECIFICATIONS

The Horizontal Ladder Back Bar Stool brings a clean, modern look that matches the dining chair version completed yesterday. Its fully welded gunmetal steel frame features a sleek horizontal ladder-back design, offering both visual appeal and long-term commercial durability. This style has become extremely popular in food courts, large mall eateries, fast-casual restaurants, and open-concept dining areas where operators demand dependable seating that can handle constant public traffic. Engineered with a 350 lb weight capacity, this bar stool delivers the strength required for high-volume environments while remaining lightweight enough for staff to move and clean around easily. The seat can be upholstered in any commercial-grade vinyl color, giving designers flexibility to coordinate with branding or interior themes. A proven, modern seating solution built for performance.

Width: 17"

Depth: 16"

Height: 41"

Seating Size: 17"W x 16"D

Seat Height: 30"

Weight: 15.5 lbs





SKU: HF-34BS



PRODUCT SPECIFICATIONS

This contemporary two-tone chair is designed for comfort, visual appeal, and modern elegance. The smooth barrel-back shape naturally hugs the body, allowing guests to relax into the chair with full back support during meals, drinks, or extended conversation. The interior seat and back feature a rich dark vinyl, while the outer shell showcases a contrasting light tone — a stylish combination that stands out without overpowering the room. Slim, tapered metal legs provide strength and stability while keeping the silhouette light and refined. Ideal for upscale restaurants, lounges, hotel dining, waiting spaces, and cocktail seating, this model blends comfort with design presence.

Width: 22.5"
Depth: 23"
Height: 45"
Seating Height: 30.5"
Seat 18" x 19"



SKU: DC1834





SKU: HF-N4



PRODUCT SPECIFICATIONS

The Custom Bar Stool was a highlight at many social clubs and many other places where style is the key, where visitors loved innovative vinyl upholstery designs styled with Button tufted style . Durable, stylish, and comfortable, this stool is built for bowling centers, entertainment venues, and other high-traffic spaces. Its unique look proves how a simple idea can make a big impact. Now we invite you to submit your own stitching concepts and design ideas to inspire future models.

Width: 22"

Depth: 22"

Height: 32"

Seat: Round 18"

Weight: 18.5 lbs





SKU: HF-2BS



PRODUCT SPECIFICATIONS

The backless barstool is one of the most popular seating solutions for limited-space environments, including busy bars, pubs, food courts, mall eateries, and high-traffic fast-casual dining areas. Its backless design makes it incredibly efficient, allowing guests to move freely while keeping walkways open—an essential benefit for operations with heavy foot traffic. This style also slides neatly under tables to save valuable space, maximizing capacity during peak hours. Built on a fully welded gunmetal steel frame, the stool supports up to 350 lbs, delivering exceptional stability and long-term performance. The padded commercial-grade vinyl seat can be upholstered in any color, giving operators full flexibility to match their branding or interior design. Practical, durable, and space-saving, this round barstool is a proven favorite in high-volume venues.

Width: 22"
Depth: 22"
Height: 31"
Seat: 16" Round
Weight: 18.5 lbs





SKU: HF-3BS



PRODUCT SPECIFICATIONS

The Backless Square Bar Stool is one of the most popular seating solutions for limited-space environments, including busy bars, pubs, food courts, mall eateries, and high-traffic fast-casual dining areas. Its backless design makes it incredibly efficient, allowing guests to move freely while keeping walkways open—an essential benefit for operations with heavy foot traffic. This style also slides neatly under tables to save valuable space, maximizing capacity during peak hours. Built on a fully welded gunmetal steel frame, the stool supports up to 350 lbs, delivering exceptional stability and long-term performance. The padded commercial-grade vinyl seat can be upholstered in any color, giving operators full flexibility to match their branding or interior design. Practical, durable, and space-saving, this barstool is a proven favorite in high-volume venues.

Width: 17.5"
Depth: 17.5"
Height: 32"
Seat: 17.5" x 17.5" x 2"
Weight: 19.5 lbs

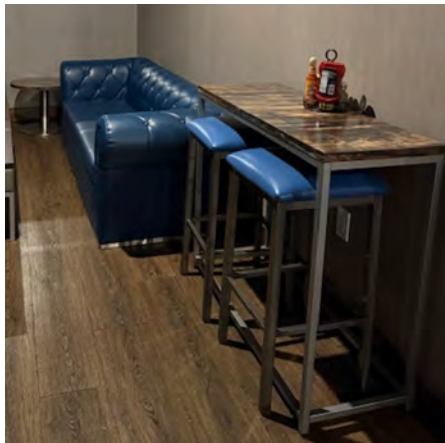

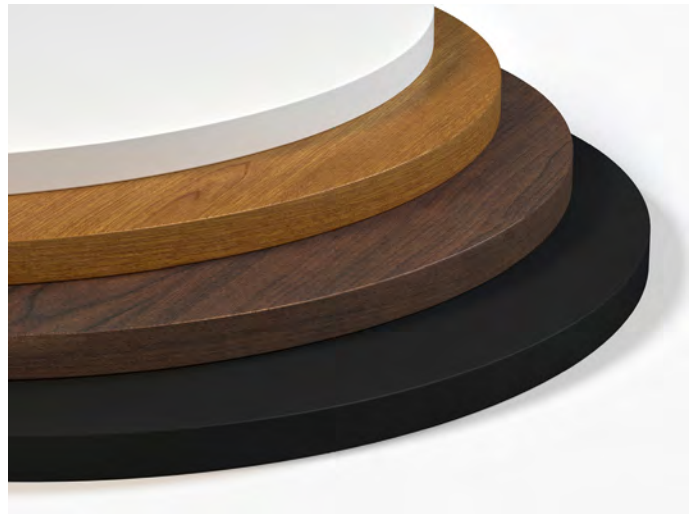

SKU: HF-LAMINATE



PRODUCT SPECIFICATIONS

Elevate the ambiance of your establishment with stylish and durable Formica Table 1" Laminate Table Top crafted to perfection, providing the unforgettable canvas for culinary experiences and social gatherings. Whether you're outfitting a restaurant or bar with these unique finishes that will make statement, our diverse range of table top colors and shapes will perfectly fit anywhere. Commercial diner tables with high quality laminate brand Formica indispensable for modern lounge furniture.

Square 24"	Square 30"	Square 36"	Square 42"	Square 48"	Square 60"
Round 18"	Round 24"	Round 30"	Round 36"	Round 42"	Round 48"
Round 60"	24" by 30"	24" by 36"	24" by 42"	24" by 48"	24" by 60"
24" by 72"	24" by 84"	24" by 96"	30" by 36"	30" by 42"	30" by 48"
30" by 60"	30" by 72"	30" by 84"	30" by 96"	36" by 42"	36" by 48"
36" by 60"	36" by 72"	36" by 84"	36" by 96"		

Wood Thickness:

2 Inches 3 Inches

Table Top Corners:

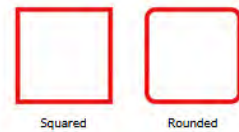

Squared

Rounded





SKU: HF-23

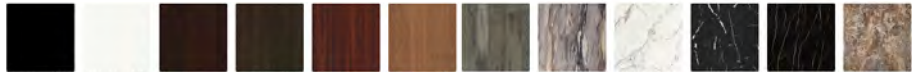

PRODUCT SPECIFICATIONS

Elevate the ambiance of your establishment with stylish and durable Formica Table 2" or 3" Laminate Table Top crafted to perfection, providing the unforgettable canvas for culinary experiences and social gatherings. Whether you're outfitting a restaurant or bar with these unique finishes that will make statement, our diverse range of table top colors and shapes will perfectly fit anywhere. Commercial diner tables with high quality laminate brand Formica indispensable for modern lounge furniture.

Square 24"	Square 30"	Square 36"	Square 42"	Square 48"	Square 60"
Round 18"	Round 24"	Round 30"	Round 36"	Round 42"	Round 48"
Round 60"	24" by 30"	24" by 36"	24" by 42"	24" by 48"	24" by 60"
24" by 72"	24" by 84"	24" by 96"	30" by 36"	30" by 42"	30" by 48"
30" by 60"	30" by 72"	30" by 84"	30" by 96"	36" by 42"	36" by 48"
36" by 60"	36" by 72"	36" by 84"	36" by 96"		

Wood Thickness:

- 2 Inches
- 3 Inches

Table Top Corners:





SKU: THICK TOP



PRODUCT SPECIFICATIONS

Make a statement at every table with our Gold or Silver Edge Table Tops — a perfect blend of style, durability, and luxury. These 2” to 3” thick commercial-grade tops are available in round, square, or rectangular shapes and feature realistic laminate finishes like Calacatta marble and Nero Marquina marble, paired with a bold gold metal edge. The result is a rich, modern aesthetic ideal for upscale restaurants, lounges, and hotels. Easy to maintain and handcrafted in the USA, these tops are built to withstand daily use while delivering high-end visual impact.

Square 24"	Square 30"	Square 36"	Square 42"	Square 48"	Square 60"
Round 18"	Round 24"	Round 30"	Round 36"	Round 42"	Round 48"
Round 60"	24" by 30"	24" by 36"	24" by 42"	24" by 48"	24" by 60"
24" by 72"	24" by 84"	24" by 96"	30" by 36"	30" by 42"	30" by 48"
30" by 60"	30" by 72"	30" by 84"	30" by 96"	36" by 42"	36" by 48"
36" by 60"	36" by 72"	36" by 84"	36" by 96"		

Wood Thickness:

2 Inches 3 Inches

Table Top Corners:

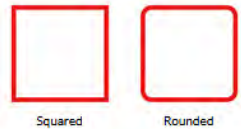



SKU: SLEEK TOP



PRODUCT SPECIFICATIONS

SLEEK TOP Performance Tops revolutionize the countertop. An engineered composite that provides impact, scratch, and moisture resistance, offering next-level durability and performance. Modern. Ultra-thin and sleek.

The sleek 1/2" profile of SLEEK TOP offers high-end aesthetics with the practical benefits of easy cleanability and resistance to stains, scratches, and impact—all with no sealing required. It's suited for a wide range of commercial spaces: hospitality, retail, offices, senior living and more. Available sizes: Square: 24", 28", 30", 36". Round: 24", 30", 36", 42", 60". Rectangular: 24"x30", 30"x48", 30"x60", 30"x72"

Black Amani: This Black marble design has thin, subtle veins that provide depth and variation throughout the design. This design has a Luster finish. Luster has a semi-gloss sheen and a smooth surface.

Calcutta Blanc: A classic, large scale Italian marble. The grey and taupe vein structure are large scale and angular and comprise the signature feature of this marble. This design has a Luster finish.

Distressed Pine: Distressed Pine is a wood design with various sized planks and is a cool color with elements of warm honey, sophisticated greys, and taupes. This design has a Wire Brush finish. Wire brushing creates a linear texture with both matte and gloss sheens.

Soapstone Mist: A large scale, smooth veined grey soapstone abounding in rich detail and natural features. This design has a Luster finish. Luster has a semi-gloss sheen and a smooth surface.



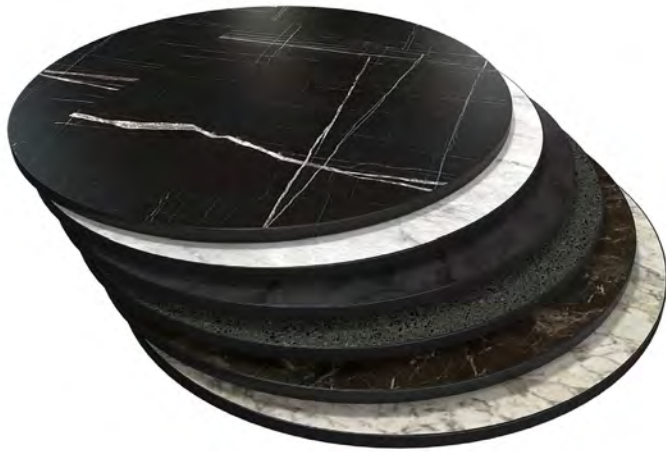

SKU: MARBLET TOP











PRODUCT SPECIFICATIONS

When performance meets elegance, you get the MARBLET Table Tops — the ideal solution for both indoor and outdoor restaurant furniture. Built on the same core composite as marine-grade Seaboard, these tops are engineered for extreme durability while featuring high-end, stone-inspired aesthetics. Designed with a protective exterior finish that resists heat, stains, scratches, and UV damage, the MARBLET collection delivers both style and strength. From sleek black marble to soft white veining, each top captures the luxury look of stone without the weight or maintenance. These composite table tops are ideal for restaurants, cafes, hotels, and rooftop venues looking for a refined, upscale look that holds up to daily commercial use — rain or shine. They are moisture resistant, anti-bacterial, impact resistant, and available in a wide range of shapes, sizes, and finishes. Whether used in a trendy indoor setting or a busy outdoor patio, MARBLET tops offer a seamless combination of beauty and reliability.

Available sizes:
 Square: 24", 28", 30", 36"
 Round: 24", 30", 36", 42", 60"
 Rectangular: 24"x30", 30"x48", 30"x60", 30"x72"



 <p>2X ABRASION RESISTANT</p>	 <p>HEAT RESISTANT UPTO 220° C</p>	 <p>HIGH SCRATCH RESISTANCE</p>	 <p>ANTI FUNGAL</p>
 <p>ANTI-BACTERIAL</p>	 <p>MOISTURE RESISTANT</p>	 <p>IMPACT RESISTANT</p>	 <p>STAIN RESISTANT</p>

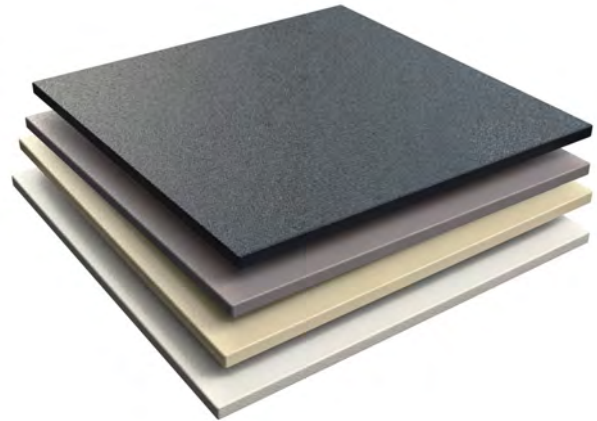

SKU: SEA-TOP



PRODUCT SPECIFICATIONS

Looking for outdoor restaurant table tops that can handle the elements year-round? Our Ultra-Durable SEA-TOP Table Tops are engineered for performance in any climate — sun, rain, or snow. Originally designed for yachts and marine applications, SEA-TOP is a waterproof, UV-resistant material that will not crack, swell, or fade. Now used in some of the most stylish restaurant patios, rooftop lounges, hotels, and outdoor cafes, it's the go-to choice for commercial-grade reliability. Available in multiple shapes, sizes, colors, and thicknesses, these all-weather out-door table tops are easy to mount on standard bases. Whether you need small café tables or large 8-person communal tables, Seaboard slabs can be cut to fit any layout. Their modern, textured surface resists wear while offering a clean, professional look. Choose from round or square options and enjoy a maintenance-free solution that performs for years — even in direct sunlight and coastal environments. If you're building a commercial outdoor dining space, Seaboard is the best material for restaurant furniture exposed to the elements.

Outdoor table tops are made from commercial marine-grade high-density polyethylene material. Will not rust, delaminate or rot when exposed to UV, humidity or water. It never needs painting or refinishing. Table top thickness is 3/4 inch.

Available sizes:

Square: 24", 28", 30", 36"

Round: 24", 30", 36", 42", 54"

Rectangular: 24"x30", 30"x48", 30"x60", 30"x72"





SKU: STANDUP

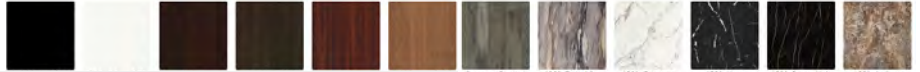

PRODUCT SPECIFICATIONS

Featured long bold-down tables provide space efficiency and encourages socializing and networking when placed in high traffic areas or can be used to accommodate large parties. Stain, scratch and impact resistant under normal use conditions. Our table are made from 1.5" thick natural wood frame and high quality industrial grade plywood, which makes this table very sturdy, heavy and ready for high usage environments. Optional USB ports and 110v outlets can be installed anywhere on the table. We can customize the ports/outlets to meet any specs and demands.

Base:
Bolt down base is all welded one piece construction (103008-43-MT)
Metal Column: 3" dia., 16 gauge steel
Weight: 12.5 lbs
Finish: Black Wrinkle

Table Dimensions:
Length: 48", 60", 72", 84 or 96"
Width: 24"
Height: 42"
Table Top Thickness: 1.5"





SKU: WALLSERVICE

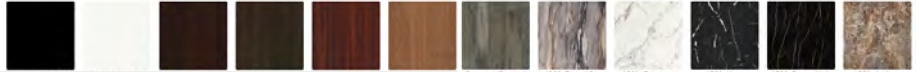

PRODUCT SPECIFICATIONS

This custom product was designed to provide baseless aesthetically appealing restaurant tables that can accommodate two or more patrons in your establishment. This very space-efficient design provides the warmth and coziness of a luxurious dining experience where the restaurant wall table is suspended in air, it's an art form in itself. The framework underneath the wood is a solid metal L-shape constructed frame that easily anchors to the wall.

Space-Saving Design: Mounted directly to the wall, this table frees up valuable floor space, creating a sleek and open environment for guests.

Customizable to Fit Your Style: Available in a variety of finishes and sizes, ensuring a perfect match with your restaurant's unique décor.

Premium Craftsmanship: Constructed from high-quality materials, this table is built to withstand the demands of busy dining establishments while maintaining a sophisticated look.

Effortless Maintenance: The wall-mounted design makes cleaning and upkeep easier, ensuring a polished and welcoming ambiance at all times.

Table Top 24" x 24" x 1.5"

Total Height: 55"

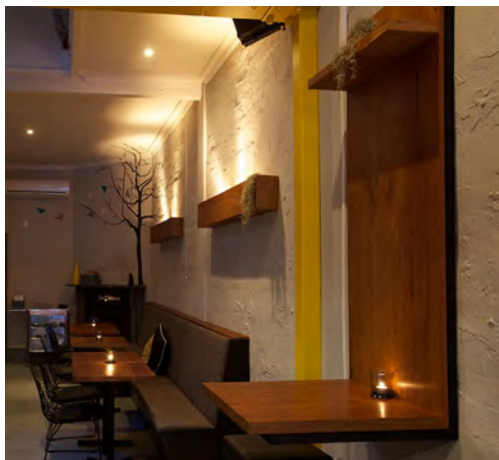



SKU: FLIPPITDOWN

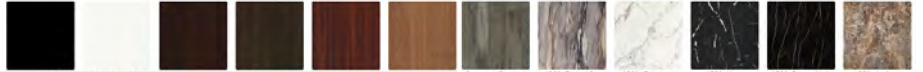

PRODUCT SPECIFICATIONS

Designed in response to real customer needs, this drop-leaf folding table is all about flexibility and visual consistency. Many restaurant owners asked for a way to match their standard laminate tables — and we delivered. Now you can add functional folding tables in the exact same color and style as your regular dining surfaces, creating a flawless, unified look throughout your space. The smart drop-leaf design features sturdy folding hinges that allow the table sides to open or close in seconds. Whether you need to seat a larger party or temporarily reduce table size, this table adapts easily to your layout. Ideal for restaurants, cafes, banquet rooms, or event spaces looking for smart solutions that don't compromise on design.

Table Top Sizes:

30" Square to 42" Round

36" Square to 51" Round

42" Square to 60" Round

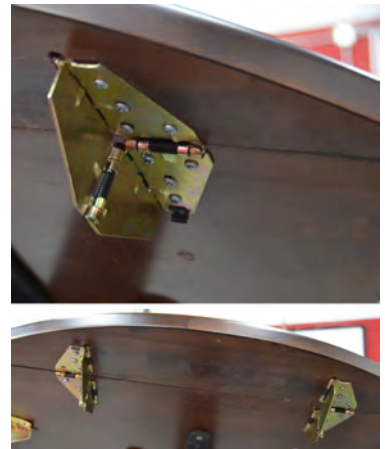



SKU: CASK TABLE

PRODUCT SPECIFICATIONS

This 36" and 96" Round Barrel Tables are designed to replicate the look of an authentic whiskey barrel, featuring a Bourbon Pine laminate finish with metal strips and rivets for a true rustic effect. The black top and base are crafted from Seaboard waterproof material — built to last a lifetime and fully sun-resistant, making it ideal for both indoor and outdoor use. Popular in beer gardens, rustic pubs, bars, and wineries, this table makes a bold statement while withstanding heavy commercial use. Durable, stylish, and low-maintenance, it's a perfect fit for any venue seeking character and long-term performance.

Length: 36" or 96"

Width: 36"

Height: 42"

Table Top Thickness: 1.125"





Base Option:

Indoor - Black Iron Cast

Outdoor - Black Zinc Undercoat

Crisscross 22" by 22" (Dining Height 28.5")

Crisscross 22" by 22" (Bar Height 40.5")

Crisscross 24" by 30" (Dining Height 28.5")

Crisscross 24" by 30" (Bar Height 40.5")

Crisscross 30" by 30" (Dining Height 28.5")

Crisscross 30" by 30" (Bar Height 40.5")

Crisscross 33" by 33" (Dining Height 28.5")

Crisscross 33" by 33" (Bar Height 40.5")

Crisscross 36" by 36" (Dining Height 28.5")

Crisscross 36" by 36" (Bar Height 40.5")

Crisscross 40" by 40" (Dining Height 28.5")

SKU: HF000

PRODUCT SPECIFICATIONS

Cross-Shaped 22" x 22" x 28.5" (Dining Height)

Indoor Option: Cast Iron Black Matte Wrinkle finish

Weight: 18 lbs

Compatible Table Tops:

Rectangular: 24" x 30"

Square: 30"

Round: 30"

Cross-Shaped 22" x 22" x 40.5" (Bar Height)

Indoor Option: Cast Iron Black Matte Wrinkle finish

Outdoor Option: Zinc Undercoat Black Powder Finish

Weight: 20 lbs

Compatible Table Tops:

Rectangular: 24" x 30"

Square: 30"

Round: 30"

Cross-Shaped 24" x 30" x 28.5" (Dining Height)

Cast Iron Black Matte Wrinkle finish

Weight: 22 lbs

Compatible Table Tops:

Rectangular: 24" x 36", 24" x 42"

Cross-Shaped 24" x 30" x 40.5" (Bar Height)

Cast Iron Black Matte Wrinkle finish

Weight: 24 lbs

Compatible Table Tops:

Rectangular: 24" x 36", 24" x 42"

Cross-Shaped 30" x 30" x 28.5" (Dining Height)

Indoor Option: Cast Iron Black Matte Wrinkle finish

Outdoor Option: Zinc Undercoat Black Powder Finish

Weight: 23 lbs

Compatible Table Tops:

Rectangular: 30" x 30", 30" x 32", 30" x 36"

Square: 36"

Round: 42"

This Traditional Crisscross Restaurant Table Base is a proven, industry-standard solution designed for everyday commercial use. Commonly found in restaurants, diners, cafés, and casual eateries, the crisscross design delivers reliable stability where function takes priority over décor. Constructed from heavy-duty cast iron, it features a durable black matte wrinkle finish for indoor use, with select models available in an outdoor-ready zinc undercoat black powder finish.

Cross-Shaped 33" x 33" x 28.5" (Dining Height)

Cast Iron Black Matte Wrinkle finish

Weight: 29 lbs

Compatible Table Tops:

Rectangular: 36" x 42", 36" x 48"

Square: 36", 42", 48"

Round: 36", 42", 48"

Cross-Shaped 33" x 33" x 40.5" (Bar Height)

Cast Iron Black Matte Wrinkle finish

Weight: 31 lbs

Compatible Table Tops:

Rectangular: 36" x 42", 36" x 48"

Square: 36", 42", 48"

Round: 36", 42", 48"

Cross-Shaped 36" x 36" x 28.5" (Dining Height)

Cast Iron Black Matte Wrinkle finish

Weight: 30 lbs

Max Table Top Size: 54" x 54"

Cross-Shaped 36" x 36" x 40.5" (Bar Height)

Cast Iron Black Matte Wrinkle finish

Weight: 21 lbs

Max Table Top Size: 48" Round

Crisscross 40" x 40" x 28.25" (Dining Height)

Cast Iron Black Matte Wrinkle Finish

Weight: 64 lbs

Spider: 24"

Column: 4"

Maximum Table Top Size: Rectangular: 60" x 60", Round: 60"



Base Option:

Indoor - Black Iron Cast

Outdoor - Black Zinc Undercoat

Set of Two Straight Legs 5" by 22" (Dining Height 28.25")

Set of Two Straight Legs 5" by 22" (Bar Height 40.25")

Set of Two Straight Legs 5" by 30" (Dining Height 28.25")

SKU: HF201

PRODUCT SPECIFICATIONS

Single Straight Leg 5" x 22" x 28.25" (Dining Height)
 Indoor Option Cast Iron Black Matte Wrinkle Finish
 Outdoor Option: Zinc Undercoat Black Powder Finish
 Weight: 7 lbs
 Maximum Table Top Size: Rectangular: 36" x 54" (with two bases)

Single Straight Leg 5" x 22" x 40.25" (Bar Height)
 Indoor Option: Cast Iron Black Matte Wrinkle Finish
 Weight: 8 lbs
 Maximum Table Top Size: Rectangular: 36" x 54" (with two bases)

Single Straight Leg 5" x 30" x 40.25" (Bar Height)
 Cast Iron Black Matte Wrinkle Finish
 Weight: 15 lbs
 Maximum Table Top Size: Rectangular: 42" x 54" (with two bases)

This Straight-Leg Restaurant Table Base (Set of Two) is designed to support large rectangular tabletops in high-traffic commercial environments. Using two independent bases allows the legs to be spaced farther apart, providing improved weight distribution and legroom compared to single-column bases. Constructed from heavy-duty cast iron, these bases deliver dependable stability and long-term durability. Finished in black matte wrinkle for indoor use, with an optional outdoor-ready zinc undercoat black powder finish, they are suitable for a wide range of restaurant and hospitality applications. A third base can be added for extra support on oversized tabletops, making this system highly adaptable.





SKU: HF308

PRODUCT SPECIFICATIONS

Dining Height: 28.5" | Bar Height 40.5"

Base Plate: 7.5" dia., 16ga. metal cover over 5/16"t thick steel plate

Top Plate: 12"x12" square stamped steel

Metal Column: 3" dia., 16 gauge steel

Finish: Black Wrinkle

Weight: 10.5 Lbs (Dining) and 12.5 lbs (Bar)

All welded one piece construction

Maximum Table Top Size: 32" Square / 36" Round

This Commercial Bolt-Down Restaurant Table Base is specifically designed to be permanently bolted to the floor, providing maximum stability in high-traffic public environments. Ideal for food courts, fast-casual restaurants, cafeterias, and institutional settings, the fixed installation helps prevent table movement, tipping, or repositioning. Constructed from heavy-duty steel with a durable black finish, this base is built for long-term commercial reliability. Available in both dining and bar heights, it supports a wide range of tabletop applications while maintaining a clean, minimal footprint. Bolt-down installation ensures safety, consistency, and a professional, organized layout.





SKU: SQUARE 5

PRODUCT SPECIFICATIONS

Designed for high-traffic commercial environments, this Dining & Bar Height Square Restaurant Table Base delivers a perfect balance of strength, style, and versatility. Crafted from durable aluminum alloy, it is lightweight yet exceptionally sturdy for long-term use in restaurants, cafés, and hospitality venues. Available in brushed steel or black matte finishes, this base is suitable for both indoor and outdoor applications. The sleek square column and low-profile square plate create a clean, contemporary look that elevates any laminate tabletop. Adjustable leveling feet ensure stability on uneven floors, while multiple size and height options accommodate tabletops up from Dining Height to bar Height.

Square 17.5" x 17.5" x 28"
Maximum Table Top Size: 36" Square

Square 17.5" x 17.5" x 40"
Maximum Table Top Size: 36" Square

Square 29" x 29" x 28"
Heavy duty low profile base. Maximum Table Top Size: 54" x 54", 54" Round
Weight 73 lbs

Square 29" x 29" x 40" Heavy duty low profile base. Maximum Table Top Size: 54" x 54", 54" Round
Weight 90 lbs





SKU: WRAP BASE 5



PRODUCT SPECIFICATIONS

The Premium Wrapped Single Column Metal Table Base Collection blends modern construction with a range of visually rich finishes, offering interior designers the freedom to express identity without sacrificing durability. Each base begins with a welded steel core, then is wrapped by hand using CNC-cut laminate panels for precise grain, pattern and color alignment. High-pressure bonding ensures a smooth, seamless surface built for continuous commercial traffic, while maintaining the remarkable aesthetic of real marble, wood, metallic gold, painted art textures or solid contemporary tones.

Available in Calacatta Marble, Warm Woodgrain, Premium Gold, Solid White, and Graffiti Brick Pattern and many more from Formica and Wilsonart brand, these bases allow restaurants, cafés, hotels, lounges and entertainment venues to tailor their atmosphere with ease. Each finish pairs beautifully with quartz, butcher-block, stone, matte or high-gloss tabletops. For operators seeking style, durability, and full creative expression, this wrapped base system is an elevated and highly versatile solution.

- Square 17.5" x 17.5" x 28" | Maximum Table Top Size: 36" Square
- Square 17.5" x 17.5" x 40" | Maximum Table Top Size: 36" Square
- Square 29" x 29" x 28" | Maximum Table Top Size: 54" x 54", 54" Round
- Square 29" x 29" x 40" | Maximum Table Top Size: 54" x 54", 54" Round





SKU: ALLOY BASE 4

PRODUCT SPECIFICATIONS

Designed for high-traffic commercial environments, this Round Dining & Bar Height Restaurant Table Base delivers exceptional stability and modern style. Durable aluminum alloy and finished in brushed steel or black matte for indoor and outdoor use. The round base design pairs perfectly with round table tops, creating a balanced, visually striking presentation in restaurants, cafés, and hospitality spaces. Heavy-duty configurations support many sizes of the table tops, while adjustable leveling feet ensure stability on uneven floors. Built for reliability, durability, and clean contemporary appeal, this base is ideal for demanding commercial settings.

Round 21" x 28.5" | Maximum Table Top Size: 36" Round

Round 21" x 40" | Maximum Table Top Size: 30" Round

Round 29", Height 28.5" (Black Matte Only)
Maximum Table Top Size: 54" x 54", 54" Round
Heavy duty - Weight 73 lbs

Round 29", Height 40.25" (Black Matte Only)
Maximum Table Top Size: 54" x 54", 54" Round
Heavy duty - Weight 90 lbs





SKU: ALLOY BASE 3

PRODUCT SPECIFICATIONS

Engineered for high-traffic commercial environments, this Rectangular Dining & Bar Height Restaurant Table Base is designed to support larger tabletops with superior stability. Constructed from durable aluminum alloy, the double-column design is mounted on a single rectangular plate to evenly distribute weight and reduce movement in busy hospitality settings. Available in brushed steel or black matte finishes, this base is suitable for indoor and outdoor use. Adjustable leveling feet ensure a perfectly balanced setup on uneven floors. Ideal for restaurants, cafés, and bars, it accommodates rectangular tabletops up to 30" x 60", delivering a clean, modern look with dependable commercial performance.

Rectangle 16" x 32" x 28" (Dining Height)
Maximum Table Top Size: 30" Width / 42" Length

Rectangle 16" x 32" x 40" (Bar Height)
Maximum Table Top Size: 30" Width / 42" Length



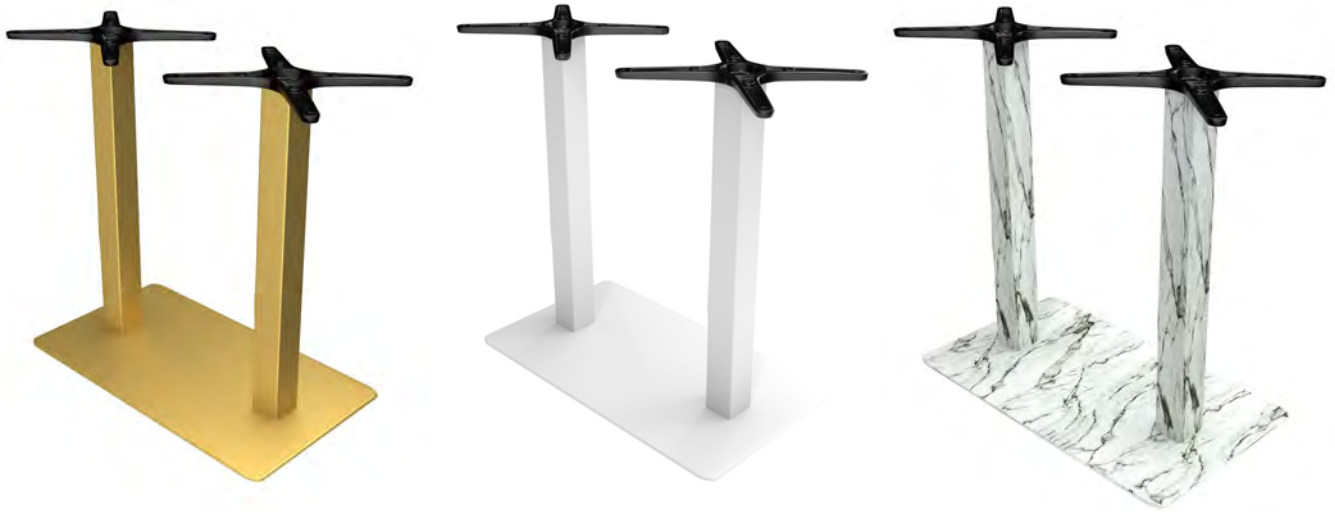

SKU: WRAP BASE 3



PRODUCT SPECIFICATIONS

The Premium Wrapped Double Column Metal Table Base Collection blends modern construction with expanded strength, supporting larger tabletops while offering a range of visually rich finishes. With a reinforced dual-post steel core, each base delivers enhanced stability for banquet-length surfaces and high-traffic hospitality environments. Both columns and the bottom plate are wrapped by hand using CNC-cut laminate panels for precise grain, pattern and color alignment. High-pressure bonding ensures a smooth, seamless finish capable of continuous commercial use, while replicating the visual beauty of real marble, wood, metallic gold, creative art patterns or solid modern tones.

Available in Calacatta Marble, Warm Woodgrain, Premium Gold, Solid White, and Graffiti Brick Pattern, these bases allow restaurants, cafés, hotels, lounges, simulator rooms and entertainment venues to set a mood with ease. Each finish pairs beautifully with quartz, butcher-block, stone, matte and polished tabletops. For operators seeking style, scale, and complete creative freedom, this double-column wrapped base system is a highly versatile and elevated design solution.

Rectangle 16" x 32" x 28" (Dining Height)
 Maximum Table Top Size: 30" Width / 42" Length

Rectangle 16" x 32" x 40" (Bar Height)
 Maximum Table Top Size: 30" Width / 42" Length





SKU: COMMUNAL - KD30



PRODUCT SPECIFICATIONS

Communal table is a new restaurant concept durable and reliable foundation that increases the number of seats in smaller spaces thus potentially boosting restaurant and bar seating sales as well playing a crucial role in developing a better Communal Lounge seating experience for customers. It also raises a restaurant's and Hotel profits by expanding the number of guests that it can serve. Communal tables can take place in public establishments like Hotel Lobbies, College cafeterias, Medical offices etc..

Our table are made from 4" thick natural wood frame and high quality industrial grade plywood, which makes this table very sturdy, heavy and ready for high usage environments.

We can create this communal bar table in any laminate, finish, size and custom own materials.

Optional USB ports and 110v outlets can be installed anywhere on the table. We can customize the ports/outlets to meet any specs and demands. Hand made in New Jersey

Dimensions:

Length: 8 feet

Width: 30"

Height: 30"

Weight: 8 foot table = 300 lbs

Optional Charging Stations
USB & 110v OUTLETS





SKU: COMMUNAL-KD42



PRODUCT SPECIFICATIONS

Communal table is a new restaurant concept durable and reliable foundation that increases the number of seats in smaller spaces thus potentially boosting restaurant and bar seating sales as well playing a crucial role in developing a better Communal Lounge seating experience for customers. It also raises a restaurant's and Hotel profits by expanding the number of guests that it can serve. Communal tables can take place in public establishments like Hotel Lobbies, College cafeterias, Medical offices etc.

Our table are made from 4" thick natural wood frame and high quality industrial grade plywood, which makes this table very sturdy, heavy and ready for high usage environments. We can create this communal bar table in any laminate, finish, size and custom own materials. Optional USB ports and 110v outlets can be installed anywhere on the table. We can customize the ports/outlets to meet any specs and demands. Hand made in New Jersey

- Length: 8 feet
- Width: 30"
- Height: 42"
- Weight: 8 foot table = 325 lbs





SKU: COMMUNAL-41

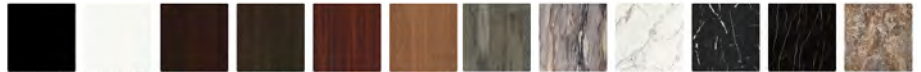

PRODUCT SPECIFICATIONS

This 42" high communal bar table is more than just a gathering space—it's a modern power hub, built to serve high-traffic environments like universities, schools, airports, cafes, and public lounges. Featuring elevated charging stations with both USB and 110V outlets above the table-top, it offers easy access for multiple users to plug in and stay connected without reaching underneath or fumbling for cords. The fully welded gunmetal steel frame is Made in the USA and engineered for unmatched strength, capable of supporting heavy loads and daily use. Unlike knockdown frames with bolts or screws, this table arrives solid and ready for action. The bold, customizable laminate surface adds a visual pop while resisting scratches and wear. Whether used for studying, eating, collaborating, or recharging—both devices and energy—this table is the ultimate fusion of utility, durability, and style. It's a true staple for any modern communal space.

Designed specifically for applications such as hospitality, contract, health care and education. Common applications are: campuses, libraries, great for public spaces such as lobbies, doctor's / law offices and conference rooms.

Powder coated gunmetal carbon steel frame is fully welded - built to be used in high traffic areas.

Table top's laminate Formica® 2.125" - Laminate features fire resistance. Stain, scratch and impact resistant under normal use conditions.

Optional 2x USBs and 1 outlet per each corner of the privacy divider, totaling 8x USBs and 8x 110v Outlets.

Charging Table: Length 84" | Width 36" | Height 42"

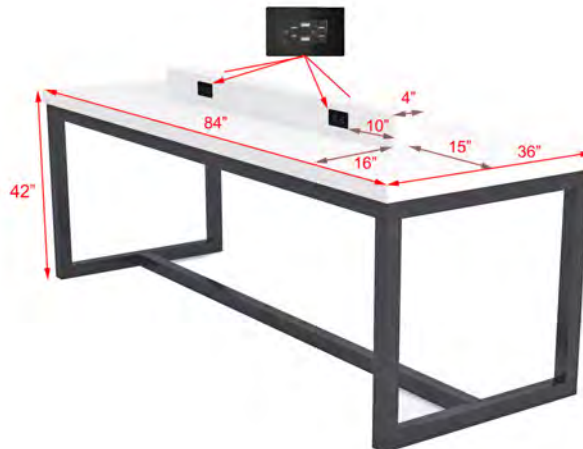



SKU: COMMUNAL-42

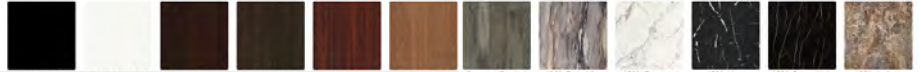

PRODUCT SPECIFICATIONS

This 42” high communal table is a true workhorse — built to handle heavy use, high traffic, and serious functionality. Made in the USA with a gunmetal powder-coated steel frame and a custom laminate top (Formica® or Wilsonart®), it's engineered for strength and style.

Clients choose from multiple USB/110V charging station options and specify where they want power access installed. The long, durable surface comfortably seats 8 and fits seamlessly into schools, offices, hotels, conference rooms, and shared workspaces. Reliable, customizable, and built like a tank — this table gets the job done.

Powder coated gunmetal carbon steel frame is fully welded - built to be used in high traffic areas.
Table top's laminate Formica® 2.125” - Laminate features fire resistance. Stain, scratch and impact resistant under normal use conditions.
Optional 2x USBs and 1 outlet per each corner of the privacy divider, totaling 8x USBs and 8x 110v Outlets.

Charging Table: Length 84” | Width 36” | Height 42”





SKU: COMMUNAL



PRODUCT SPECIFICATIONS

Communal table is a new restaurant concept durable and reliable foundation that increases the number of seats in smaller spaces thus potentially boosting restaurant and bar seating sales as well playing a crucial role in developing a better Communal Lounge seating experience for customers. It also raises a restaurant's and Hotel profits by expanding the number of guests that it can serve. Communal tables can take place in public establishments like Hotel Lobbies, College cafeterias, Medical offices etc..

Our table are made from 4" thick natural wood frame and high quality industrial grade plywood, which makes this table very sturdy, heavy and ready for high usage environments. Optional USB ports and 110v outlets can be installed anywhere on the table.

Length: 96"
Width: 36"
Height: 42"



SKU: SIGMA-42-16FT



Table Top Size:

24" by 48"

24" by 60"

24" by 72"

24" by 84"

24" by 96"

SKU: HF-220088

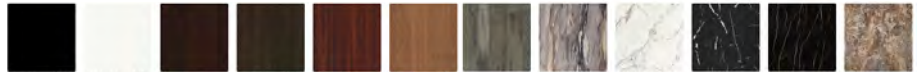

PRODUCT SPECIFICATIONS

Give your guests more than just a place to stand—give them power. The Bolt-Down Stand-Up Communal Table with 3 Integrated Power Outlets is a game-changer for high-traffic commercial spaces that value form and function. Standing 43" high, this table is ideal for cafés, airports, libraries, hotel lounges, and tech-forward public spaces. It features three flush-mounted power/USB charging stations built directly into the table's face—perfect for charging phones, laptops, or tablets while enjoying coffee or casual conversation. Crafted with a durable laminate surface (in many finish options) and secured by black metal bolt-down legs, this table is made for everyday use in demanding environments. Choose from various top thicknesses starting at 1.25" for a look that aligns with your interior aesthetic. Whether installed by a window or in the heart of a collaborative zone, this charging communal table invites people to stay longer and stay connected—one charge at a time.

Base:

Bolt down base is all welded one piece construction (103008-43-MT)

Metal Column: 3" dia., 16 gauge steel

Weight: 12.5 lbs

Finish: Black Wrinkle

Length: 48", 60", 72", 84" (come with two bolt-down bases)

Length: 96" (comes with 3 bolt-down bases)

Width: 24"

Height: 42"





SKU: HF-220084

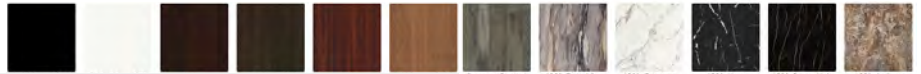

PRODUCT SPECIFICATIONS

Designed for compact commercial areas, the Bolt-Down Stand-Up Communal Table is a space-saving, high-function piece built for hospitality and public environments. Its clean design and fixed installation make it ideal for use along windows, in lobby spaces, or high-traffic zones like food halls and cafés. Standing at 42" height, this table is made for guests to comfortably stand, socialize, or enjoy a quick break. Built with a durable laminate top and sturdy black metal bolt-down bases, it offers long-term stability and resistance to wear and tear. The surface is available in many finishes and table thicknesses starting at 1.25", allowing you to customize the look to fit your brand or environment. Use it solo or pair with bar stools for added versatility. Whether you're furnishing a university hallway, co-working space, or a casual bistro, this bolt-down communal table delivers dependable performance with a sleek footprint.

Base:

Bolt down base is all welded one piece construction (103008-43-MT)

Metal Column: 3" dia., 16 gauge steel

Weight: 12.5 lbs

Finish: Black Wrinkle

Length: 84"

Width: 20"

Height: 43"

Table Top Thickness: 6"





SKU: HF24



PRODUCT SPECIFICATIONS

The HF24 Coffee Table is a simple yet powerful solution for lounges, nightclubs, and hospitality spaces that demand durability and style. Its fully welded gunmetal metal frame provides exceptional stability, ensuring long-lasting performance in high-traffic commercial environments. The elegant 2" thick tabletop—available in a wide selection of premium laminates—transforms this table into a functional piece of art. Whether paired with modular lounge seating or placed as a standalone accent, the HF24 delivers a clean, modern aesthetic while offering the strength and reliability expected from American-made commercial furniture.

Table Dimensions:

Length: 24" or 42"

Width: 24"

Height: 16"

Table Top Thickness: 2" or 3"



SKU: CT42



SKU: HF24 - GOLD



PRODUCT SPECIFICATIONS

Marble-Inspired Tables with Gold Accents Enhance your space with the luxurious appeal of our premium laminate tables, designed to mimic the beauty of Calacatta and Nero Marquina marble etc. Featuring a stunning gold-trimmed edge and sleek gold metal legs or bases, these tables bring a sophisticated, high-end aesthetic without the maintenance of real stone. The perfect fusion of modern elegance and timeless charm, they elevate any restaurant, lounge, or upscale dining space with their refined contrast and striking presence.

Featuring a laminated premium finish with Gold accented edge, this table is thoroughly protected from heat, moisture and scratches. We create each table top from scratch to meet your exact criteria. Handcrafted in USA.

Laminate features fire resistance Grade 32 / 50. Stain, scratch and impact resistant under normal use conditions.

The heavy, elegant base of the table is made from gunmetal powder coated fully-welded metal.

Table Dimensions:

Length: 24"

Width: 24"

Height: 16"

Table Top Thickness: 2"

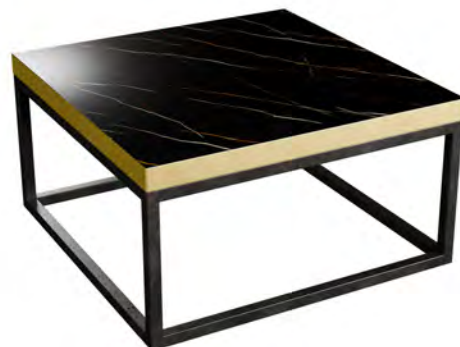



SKU: HF24 - CLUB

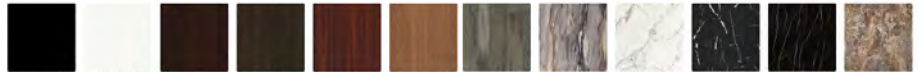

PRODUCT SPECIFICATIONS

This burn-proof hookah table is purpose-built for lounges, clubs, and outdoor spaces that demand high durability and performance. Made in the USA with a fully welded gunmetal steel frame, it's designed to hold up under the daily wear of hookah use — including heat exposure, ash, and frequent cleaning. The tabletop is crafted from non-combustible, impact-resistant materials and finished for long-term use in high-traffic environments. Whether used indoors or out, this table adds serious edge and industrial style to your layout.

Table Dimensions:
Length: 24" and 42"
Width: 24"
Height: 16"



SKU: CT42-CLUB



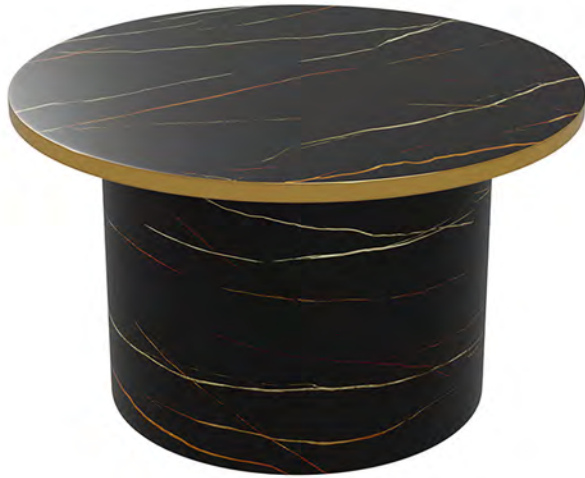

SKU: OBLIQUE TABLE



PRODUCT SPECIFICATIONS

Modern Tables with Gold Accents enhance your space with the luxurious appeal of our premium laminate tables, designed to mimic the beauty of Calacatta and Nero Sahara Noir marble etc. Featuring a stunning gold-trimmed edge and sleek gold metal legs or bases, these tables bring a sophisticated, high-end aesthetic without the maintenance of real stone. The perfect fusion of modern elegance and timeless charm, they elevate any restaurant, lounge, or upscale dining space with their refined contrast and striking presence.

Premium Formica® lounge table features fire resistance Grade 32 / 50. Stain, scratch and impact resistant under normal use conditions. This lounge table is designed specifically for applications such as hospitality, contract, health care and education. This product can have the same laminate edge as table top or satin brushed gold laminated edge.

Round 24" | Height 24"
Round 30" | Height 18"
Round 36" | Height 18"

Table Top Thickness 1"



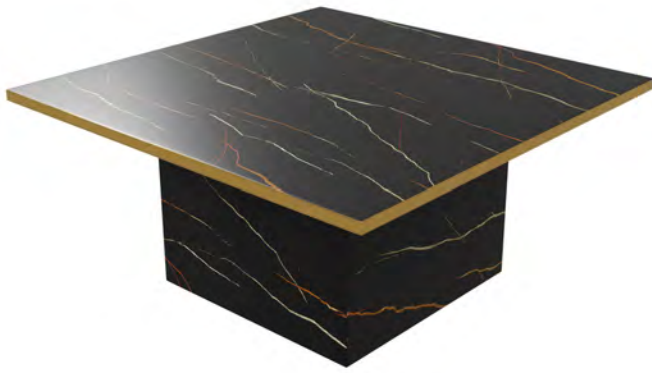

SKU: ARTEM TABLE

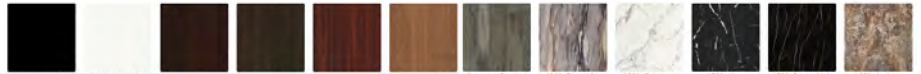

PRODUCT SPECIFICATIONS

Modern Tables with Gold Accents enhance your space with the luxurious appeal of our premium laminate tables, designed to mimic the beauty of Calacatta and Nero Sahara Noir marble etc. Featuring a stunning gold-trimmed edge and sleek gold metal legs or bases, these tables bring a sophisticated, high-end aesthetic without the maintenance of real stone. The perfect fusion of modern elegance and timeless charm, they elevate any restaurant, lounge, or upscale dining space with their refined contrast and striking presence.

Premium Formica® lounge table features fire resistance Grade 32 / 50. Stain, scratch and impact resistant under normal use conditions. This lounge table is designed specifically for applications such as hospitality, contract, health care and education. This product can have the same laminate edge as table top or satin brushed gold laminated edge.

Square 30" | Height 24"

Square 36" | Height 18"

Table Top Thickness 1"





SKU: CHARLOTTE -ST - LMNT



PRODUCT SPECIFICATIONS

This Occasional Side Table combines a fully welded steel frame with a sleek, boxy laminate top, creating a modern and versatile piece that fits seamlessly into today's hospitality environments. Its clean lines and durable construction make it ideal for hotel lobbies, lounges, office waiting areas, and high-traffic commercial spaces. Available in many laminate color options beyond walnut, this design offers both aesthetic warmth and long-lasting performance. The dark gunmetal frame adds a refined contrast, enhancing the table's contemporary appeal. Stylish, functional, and built in the USA, this table remains a popular choice among designers and hospitality professionals.

Walnut laminate Formica® side table features fire resistance Grade 32 / 50. Stain, scratch and impact resistant under normal use conditions. Please note we can customize this side table to any laminate color and finish. This side table is designed specifically for applications such as hospitality, contract, health care and education. Dark gunmetal powder coated carbon steel frame is fully welded - built to be used in high traffic areas.

Dimensions:

Width: Square 27" | Rectangle 48"

Depth: 27"

Height: 17.5"





SKU: CHARLOTTE - ST

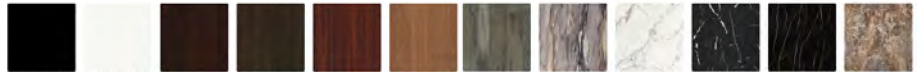

PRODUCT SPECIFICATIONS

This Modern Occasional Side Table offers a stylish blend of durability and design, featuring a fully welded dark gunmetal steel frame paired with a sleek 1” laminate top. Its unique upholstered insert allows this table to coordinate perfectly with surrounding lounge seating, creating a cohesive and upscale look in any hospitality environment. Ideal for hotel lobbies, lounges, offices, and commercial waiting areas, this versatile piece adds both function and aesthetic appeal. Available in multiple laminate and upholstery combinations, the Modern Occasional Table delivers long-lasting performance and elegant style—making it a perfect companion to any upholstered furniture set.

Dark gunmetal powder coated carbon steel frame is fully welded - built to be used in high traffic areas.
This product was designed to occupy the least amount of space while providing the maximum amount of seating.
Laminate Formica® Table Top is 1.125”. Stain, scratch and impact resistant under normal use conditions.

Dimensions:

Width: Square 27” | Rectangle 48”

Depth: 27”

Height: 17.5”





SKU: SOHO COFFEE TABLE

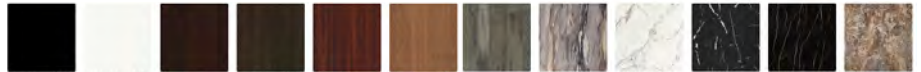

PRODUCT SPECIFICATIONS

SOHO Coffee table It's more than just a table — it's the piece that pulls the whole room together. The SOHO Coffee Table is custom-built with a solid wood core and wrapped in any laminate finish you choose, allowing you to match your space perfectly. Whether placed in a spacious hotel lobby or a modern lounge, its bold shape and seamless design instantly catch the eye. Clients often request larger sizes tables to make a visual impact — and with our made-to-order approach, it's easy to bring that vision to life. Clean, dramatic, and crafted to impress. Optional cup 3" deep holders can be installed anywhere on the table top.

We use the world's renowned very high quality laminate from Formica®. We create each table top from scratch to meet your exact criteria. Laminate features fire resistance Grade 32 / 50. Stain, scratch and impact resistant under normal use conditions.

Dimensions:

Square 36"

Square 48"

Rectangular Length: 24" Width 48"

Standard height: 17"





SKU: OMAHA ROUND TABLE



PRODUCT SPECIFICATIONS

There's a reason the OMAHA Round Table is a favorite in schools, universities, and collaborative learning spaces. Its rounded shape makes it easy to gather around, whether students are studying, relaxing, or meeting in small groups. No sharp corners means safer movement, and its open design makes getting in and out with chairs seamless — even in tight spaces. Built with a solid wood frame and finished in durable laminate, Lucas offers both resilience and design flexibility. From libraries to campus lounges, this table brings flow, comfort, and a modern feel to any educational environment and many more. Round. Ready. Right for learning.

We use the world's renowned very high quality laminate from Formica®. We create each table top from scratch to meet your exact criteria. Laminate features fire resistance Grade 32 / 50. Stain, scratch and impact resistant under normal use conditions.

Optional Charging Power Dome features 2x USB ports and 2x 110v Outlets.

Optional [4] Cup Holders measure 3.25" inside diameter and are 3" deep.

The cup holder is made of thicker, anti-rust colored anodic oxidation aluminum, features a long lip; anti-corrosion; smooth edges; resistant to damage and deformation.

Dimensions:

Round 24" or Round 30" or Round 36"

Height 18"

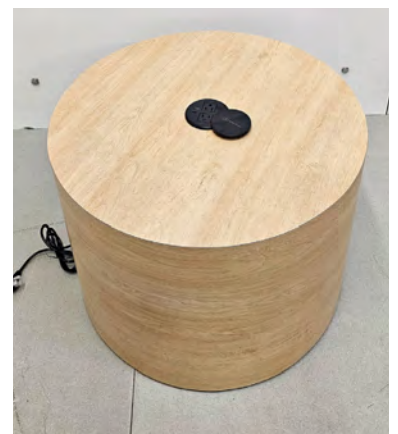



SKU: LOUNGE TABLE

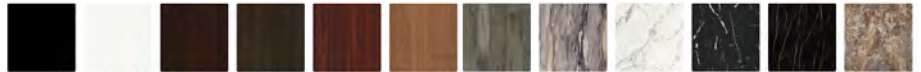

PRODUCT SPECIFICATIONS

The LOUNGE Table is a compact, versatile solution designed for lounges, hospitality spaces, and social areas where durability and mobility matter. Its fully welded steel frame provides exceptional strength, supporting up to 200 lbs on the tabletop while maintaining a clean, modern profile. The 27" square surface—available in a wide range of premium laminate finishes—offers a sleek, "bullet-proof" feel ideal for high-traffic commercial environments. Lightweight enough to reposition with ease, yet strong enough for everyday use, the LOUNGE delivers the perfect balance of function and style. Made in the USA and built for long-term performance in any professional setting.

Dimensions:
Width: 27" or 48"
Depth: 27"
Height: 12"



SKU: CT2748



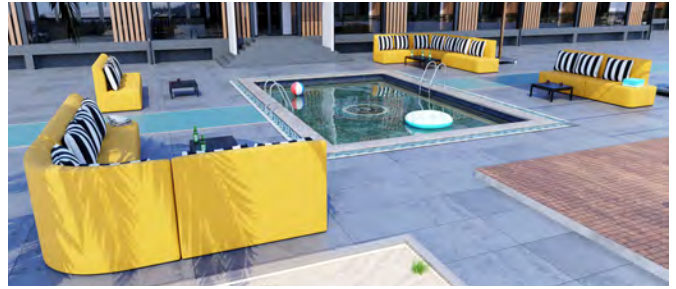

SKU: ROYALTY OUTDOOR



PRODUCT SPECIFICATIONS

The ROYALTY Outdoor U-Shape Seating System is a truly one-of-a-kind outdoor lounge solution, engineered for venues that demand elevated comfort, modern design, and long-term outdoor durability. What makes this model unique is its internal marine-grade Starboard structural frame, fully upholstered on all sides with quick-dry foam and premium Sunbrella fabric. This construction method is extremely rare in the outdoor furniture industry and places the ROYALTY in a class of its own.

The use of Sunbrella fabric, paired with quick-dry foam, allows the seating to dry rapidly after rain while remaining resistant to fading, moisture, and mildew. Adding to its visual appeal, the two-tone decorative pillows introduce bold color contrast, making the ROYALTY even more inviting, stylish, and desirable for today's high-end outdoor environments.

Ideal for resorts, pool decks, rooftop lounges, cabanas, and beachfront venues, the ROYALTY Outdoor Seating System delivers unmatched comfort with standout design and rare construction innovation.

Dimensions

Length: 72" x 144" x 72"

Depth: 27"

Height: 34"

Seating Height: 16.5"

Seating Depth: 21"

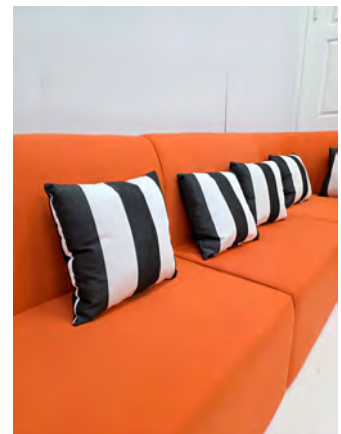



SKU: ISABELLA OUTDOOR



PRODUCT SPECIFICATIONS

The ISABELLA Outdoor Modular U-Shape Lounge Seating is a powerful combination of American-made steel construction, modern retro design, and long-term outdoor performance. Engineered specifically for demanding commercial environments, this seating system delivers the durability required for rooftop lounges, hotel outdoor areas, pool decks, entertainment venues, and high-traffic hospitality spaces.

At the foundation of the ISABELLA system is its UV powder-coated steel frame, manufactured in the USA using 1" heavy-duty steel tubing for superior structural integrity. This reinforced frame design provides exceptional strength and stability for daily commercial use while protecting the metal against sun exposure, corrosion, and outdoor wear. The modular construction allows each unit to be easily secured using heavy-duty connectors, giving designers complete flexibility to build U-shape layouts, L-shape configurations, or long straight seating runs that adapt seamlessly to any space.

The design profile of the ISABELLA delivers a retro-modern aesthetic, blending clean horizontal lines with industrial strength for a look that works equally well in upscale rooftop lounges or vibrant poolside settings. Comfort is elevated through the use of premium Sunbrella upholstery, engineered for outdoor performance with exceptional resistance to fading, moisture, mildew, and stains. Backed by a 5-year Sunbrella fabric warranty, this system offers long-term peace of mind for commercial operators.

Lounge Seating:

Length: 116" x 138" x 116" | Width: 27" | Height: 29" | Seating Height: 15" | Seating Depth: 24" | Each Arm: 2"





Frame Seaboard® Finishes:

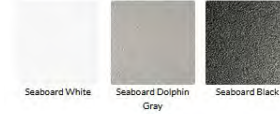

SKU: GABRIELLA OUTDOOR



PRODUCT SPECIFICATIONS

The GABRIELLA Outdoor Modular U-Shape Seating is expertly crafted for today’s most demanding outdoor environments, where durability, design, and comfort must work together seamlessly. This model is built using only premium outdoor-rated materials, making it an ideal solution for rooftop lounges, pool decks, restaurant patios, and open-air hospitality spaces. At the core of the GABRIELLA’s strength is its marine-grade Starboard frame, which is 100% all-weather proof, moisture resistant, UV stable, and maintenance-free. Each structural component is precision-cut using CNC machinery, ensuring perfect alignment, consistency, and long-term reliability. Designed to perform under commercial stress, each seat is engineered to support up to 400 lbs, while the heavy-duty frame construction provides exceptional stability even in high-wind conditions. The weight and structural integrity of the frame prevent movement and shifting, making it ideal for exposed rooftop and coastal installations.

Outdoor Seaboard frames are made from commercial marine-grade high-density polyethylene material. Suitable for all high traffic indoor and outdoor environments, especially in the restaurants and hospital industry. Has a beautiful top teak texture which reduces slip and provides durability against scratches. A unique and advanced, high-density polyethylene building sheet that lasts a lifetime. It is environmentally stabilized to withstand the harshest outdoor conditions. Will not rust, delaminate or rot when exposed to UV, humidity or water. It never needs painting or refinishing

Overall Length: 90” x 142” x 90”
 Depth: 32” | Height: 34” | Seating Height: 18.5” | Seating Depth: 22” | Seat Cushion: 5”





SKU: LIAM BOOTH



PRODUCT SPECIFICATIONS

The LIAM Outdoor U-Shape Seating System is one of the most visually striking and versatile outdoor lounge solutions available for today's high-end commercial environments. What immediately sets the LIAM apart is its unique angled back design, created to enhance ergonomic support while elevating the overall look of the seating. This thoughtful backrest geometry provides exceptional comfort for guests of all sizes, allowing them to lounge, socialize, and relax for extended periods. The result is a seating system that feels as good as it looks—ideal for venues seeking a design-forward atmosphere that also performs commercially.

Outdoor frames are fully welded UV-resistant aluminum in a gloss white finish. Suitable for all high traffic indoor and outdoor environments, especially in the restaurants and hospital industry.

- Overall Length: 90" x 142" x 90"
- Depth: 32"
- Height: 34"
- Seating Height: 18.5"
- Seating Depth: 22"
- Seat Cushion: 5"





SKU: RIVERIA OUTDOOR



PRODUCT SPECIFICATIONS

This curved outdoor radius seating model is one of the most popular and visually striking designs in outdoor hospitality today. Its distinctive rounded layout instantly transforms any outdoor space into a destination, creating a unique flow that standard straight seating simply cannot achieve. Widely used in all-inclusive resorts, luxury hotels, poolside lounges, and beachfront properties, this model is designed for venues that aim to impress and create memorable guest experiences. Upholstered in premium Sunbrella fabric with a 5-year warranty, this seating system offers outstanding resistance to fading, moisture, and commercial wear, making it a reliable, long-term outdoor investment.

Outdoor frames are fully welded UV-resistant aluminum in a gloss white finish. Suitable for all high traffic indoor and outdoor environments, especially in the restaurants and hospital industry.

- Overall Dimensions
- Length: 75"
- Depth: 50"
- Height: 29"
- Seating Height: 19"
- Seating Depth: 22"

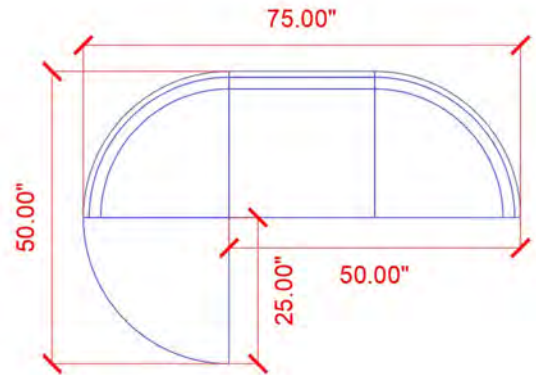



SKU: EASY DINING OUTDOOR



PRODUCT SPECIFICATIONS

This table top is made from commercial marine-grade high-density Seaboard material. Seaboard is suitable for all high traffic indoor and outdoor environments, especially in the restaurants and hospital industry. This table has a beautiful top teak texture which reduces slip and provides durability against scratches. Seaboard is a unique and advanced, high-density polyethylene building sheet that lasts a lifetime. Seaboard has a matte finish on both sides It is environmentally stabilized to withstand the harshest outdoor conditions. Seaboard will not rust, delaminate or rot when exposed to UV, humidity or water. It never needs painting or refinishing

Table top thickness is 3/4 inch. Table Top is 36" Round. Overall table height with base is 30"
 Custom bevel edges and table top sizes are available.

Table Base has a low profile design, smooth black powder coated alloy with zinc undercoat
 Restaurant chair has gunmetal powder coated frame finish, 18 gauge steel frame fully welded joint assembly, with high-density marine-grade Seaboard planked back and seat.

Restaurant chair dimensions: Width 18" | Depth 21" | Height 34"





SKU: OF-G3



PRODUCT SPECIFICATIONS

This table top is made from commercial marine-grade high-density Seaboard material. Table base's column is cast iron black powder coated finish with a Seaboard black bottom plate. Seaboard is suitable for all high traffic indoor and outdoor environments, especially in the restaurants and hospital industry. Seaboard is a unique and advanced, high-density polyethylene building sheet that lasts a lifetime. Seaboard has a matte finish on both sides It is environmentally stabilized to withstand the harshest outdoor conditions. Seaboard will not rust, delaminate or rot when exposed to UV, humidity or water. It never needs painting or refinishing

Table top thickness is 3/4 inch. Table Top is 24" x 48". Overall table height with base is 42"
 Custom bevel edges and table top sizes are available.

Bar Stool has gunmetal powder coated frame finish, 18 gauge steel frame fully welded joint assembly, with high-density marine-grade Seaboard planked seat.

Bar Stool dimensions: Width 18" | Depth 21" | Height 41"





SKU: MT2-84-OUTDOOR-441DC



PRODUCT SPECIFICATIONS

This 7' table top is made from commercial marine-grade high-density Seaboard material. This table has a beautiful top teak texture which reduces slip and provides durability against scratches. Seaboard is a unique and advanced, high-density polyethylene building sheet that lasts a lifetime. Seaboard has a matte finish on both sides. It is environmentally stabilized to withstand the harshest outdoor conditions. Seaboard will not rust, delaminate or rot when exposed to UV, humidity or water. It never needs painting or refinishing. Frame is UV powder coated carbon steel - fully welded frame - built to be used in high traffic areas.

Table Specs:
 Table top thickness is 3/4 inch
 Table Top is 36" x 84"
 Dining height of 30"

Chair Specs:
 Width: 18"
 Depth: 21"
 Height: 34"
 18 gauge steel frame with welded joint assembly
 Powder coated Gunmetal frame finish





SKU: SLEEK OUTDOOR



PRODUCT SPECIFICATIONS

This 7' table top is made from commercial marine-grade high-density Seaboard material. This table has a beautiful top teak texture which reduces slip and provides durability against scratches. Seaboard is a unique and advanced, high-density polyethylene building sheet that lasts a lifetime. Seaboard has a matte finish on both sides. It is environmentally stabilized to withstand the harshest outdoor conditions. Seaboard will not rust, delaminate or rot when exposed to UV, humidity or water. It never needs painting or refinishing. Frame is UV powder coated carbon steel - fully welded frame - built to be used in high traffic areas.

Table Specs:
Table top thickness is 3/4 inch
Table Top is 36" x 84"
Bar height of 42"

Bar Stools Specs:
Width: 17"
Depth: 17"
Height: 30"
18 gauge steel frame with welded joint assembly
Powder coated Gunmetal frame finish





SKU: SCANIA-AIR



PRODUCT SPECIFICATIONS

Whether in lobbies or public areas, or casual meeting environments and touchdown spaces, This Modern Commercial chair abounds with possibilities. Lounge chairs with casters or Metal Frame make an excellent choice for workgroups – the ever growing collaborative work style. Rotating tablet or pull-up table and Heavy duty commercial and functional chair becomes the gateway to productive freedom. Yet for all its functionality, Scania is equally pleasing in traditional lounge settings where simply waiting in comfort is all that is required.

Overall seating length: 72" | Overall seating width: 27"

Center console table:

Laminate features stain, scratch and impact resistant under normal use conditions. 1x Power Outlet has [2x] USB and [2x] 110v ports.

Width: 19"

Length: 27"

Chair Dimension:

Length: 27"

Depth: 27"

Height: 34"

Seating Depth: 21"

Seating Height: 18"





SKU: VICTOR-AIR-12



PRODUCT SPECIFICATIONS

Whether in lobbies or public areas, or casual meeting environments and touchdown spaces, This Modern Commercial chair abounds with possibilities. Lounge chairs with casters or Metal Frame make an excellent choice for workgroups – the ever growing collaborative work style. Rotating tablet or pull-up table and Heavy duty commercial and functional chair becomes the gateway to productive freedom. Yet for all its functionality, Scania is equally pleasing in traditional lounge settings where simply waiting in comfort is all that is required.

Center console table IS Stain, scratch and impact resistant under normal use conditions.

1x Power Outlet has [2x] USB and [2x] 110v ports.

Width: 13”

Length: 27”

Chair Dimension:

Length: 37.5”

Depth: 27”

Height: 28”

Seating Depth: 21”

Seating Height: 17.5”

Overall seating length: 84”

Overall seating width: 28”





SKU: CUBIC PACKAGE



PRODUCT SPECIFICATIONS

The CUBIC Package is a fully integrated seating solution designed for high-traffic environments like airports lounge furniture, furniture libraries, and universities, schools, and corporate lounges. Made in the USA using fully welded steel frames, this unit offers lasting durability with upholstered seats available in premium vinyl or fabric.

Each pod includes privacy dividers and built-in USB/110V power stations, making it ideal for study, work, or relaxation. Whether Furniture is placed in an airport terminal, student lounge, or public library, the CUBIC Package delivers smart design and maximum functionality.

Durable. Comfortable. Built for modern public spaces.

Design the ideal study room. These study and work capsules provide a personal area to accomplish tasks or simply relax and refocus, recharge your devices and enjoy a bit of privacy.

Console table is stain, scratch and impact resistant under normal use conditions.

1x Power Outlet has [2x] USB and [2x] 110v ports.

Width: 10"

Length: 26"





SKU: SAVANNAH PACKAGE



PRODUCT SPECIFICATIONS

The SAVANNAH Package is the ultimate solution for schools, libraries, event spaces, and educational facilities seeking flexible, tech-ready seating. Designed with mobility in mind, each modular Stella sofa features built-in casters, making rearrangement fast and easy for both students and staff. Equipped with integrated power outlets, this package promotes learning and collaboration by allowing users to stay connected while lounging comfortably. Paired with sleek 30" round console tables, this setup provides practical surfaces for laptops, books, and snacks—perfect for student lounges, campus break areas, or event green rooms.

How it works: this bright and inviting armless loveseat was created to allow for easy mobility, so it can be either moved to a desired position quickly or out of the way. The front of the loveseat has two casters, so when the sofa is lifted towards the front, by using the rear handles, the loveseat now is able to be easily moved.

Built in the USA using commercial-grade materials, this seating solution balances style, function, and durability. If you're looking to modernize your space with student-friendly lounge seating, this package delivers smart, high-impact design.

- Length: 48"
- Depth: 25.5"
- Height: 36"
- Seating Depth: 19.5"
- Seating Height: 18.5"





SKU: CASINO-LOUNGE-PACKAGE



PRODUCT SPECIFICATIONS

Casinos thrive on comfort, ambiance, and guest engagement — and the Casino Lounge Package delivers all three. Designed and Made in the USA, this collection elevates casino and entertainment spaces with a perfect blend of luxury, durability, and modular flexibility.

This setup features elegant Modern Sofas paired with fully upholstered Club Chairs for personal comfort and style. The matching Round Lounge Tables serve as functional centerpieces, ideal for holding drinks, snacks, or personal items.

Part of the Casino Collection, this design encourages social interaction while maintaining the upscale aesthetic expected in modern casinos and resorts.

Perfect for casinos, resorts, and VIP lounges, the Casino Package creates a refined atmosphere that keeps guests comfortable, relaxed, and engaged.

Casino Sofa: Width: 73” (3-Seater) | Depth: 27” | Height: 28” | Seating Height 17.5” | Seating Depth: 21”

CB88 Club Chair: Width: 29.5” | Depth: 30” | Height: 34” | Seating Height: 18” | Seating Depth: 20”





SKU: LEON-Z-CASINO-PACKAGE



PRODUCT SPECIFICATIONS

In every casino or gaming lounge, seating plays a powerful role in how long guests stay — and how much they enjoy their experience. The Leon-Z Casino Furniture Package delivers that perfect balance of comfort, durability, and design sophistication, all proudly Made in the USA.

This setup showcases a refined mix of Modern Sofas and Modern Chairs from the Leon Furniture Collection — a line celebrated for its ergonomic comfort and elegant presence. The signature armrests wrap smoothly around each frame, offering a sculpted shape and inviting feel that encourages guests to relax and stay longer.

Durable, commercial-grade construction ensures this furniture withstands the constant use typical of casinos and entertainment venues. The coordinated lounge tables with cup holders add both functionality and style, providing convenient surfaces for drinks, snacks, and personal items.

With its combination of luxurious materials, modular flexibility, and timeless design, the Leon-Z Casino Package elevates every gaming space — keeping guests comfortable, engaged, and coming back for more.

Leon-Z Sofa: Width: 73” (3-Seater) | Depth: 27” | Height: 32” | Seating Height 17” | Seating Depth: 20”

Leon-Z Chair: Width: 27” | Depth: 27” | Height: 32” | Seating Height: 17” | Seating Depth: 20”

Chelsea Lounge Table: Length: 24” | Width 48”

Standard height: 17”



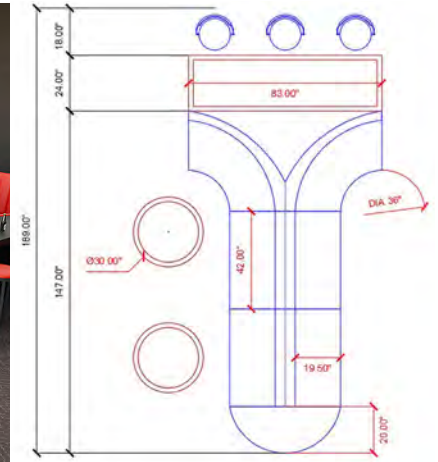

SKU: STRIKE-PACKAGE



PRODUCT SPECIFICATIONS

The Strike Bowling Seating Package became the highlight of the 2025 International Bowling Expo in Washington, DC, proving to be the most popular choice among bowling centers. Designed with versatility in mind, this Modular Lounge Seating adapts easily to different facility sizes and group needs. By adding or removing components, operators can create layouts that maximize space, comfort, and traffic flow. Featuring premium channel-back upholstery, vibrant red-black design, and bar stools, the Strike model delivers both durability and style. Handcrafted in the USA, it's the ultimate seating solution for bowling alleys seeking flexibility and modern appeal.

- Designing modular furniture for bowling centers requires balancing functionality, aesthetics, durability, and adaptability.
- Maximize seating capacity: Modular furniture should accommodate groups of varying sizes without overcrowding the area.
- Clear pathways: Ensure furniture placement allows easy movement for bowlers and staff, particularly around lanes and scoring areas.
- Flexible configurations: Use modular designs to rearrange seating and tables to fit different group sizes or event requirements.
- Modern design: Match the center's overall theme with sleek, modern furniture that appeals to a wide audience.
- Branding opportunities: Integrate custom colors, or patterns that reflect the bowling center's identity.
- Comfort: Included ergonomic seating and tables for guests who may spend hours at the center.
- Multi-purpose design: Provide furniture that supports eating, socializing, and spectating without disrupting the flow of the game.
- Scalability: Our furniture can easily expand or contract to meet changing capacity needs.





SKU: STYLE-S-BOWLING-PACKAGE

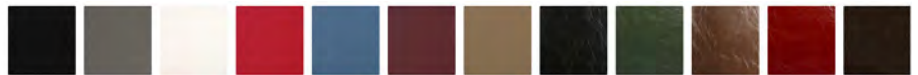

PRODUCT SPECIFICATIONS

One of our most popular modular lounge seating with only a few components to create many seating configurations..

Upholstery Kelton Writer's Block Collection:

Offers a winning combination of lightly pebbled leather texture style, performance, and practicality, making it a popular choice for upholstery projects requiring both durability and aesthetic appeal. Superb performance commercial grade-fabric with 250,000 double rubs. Phthalate free and Lead free. It is California TB 117 fire code certified.

The 19" depth seating surface allows for ample seating space and comfort. This product was designed to occupy the least amount of space while providing the maximum amount of seating. Frame is built of solid hardwood. Cushion is made of high density CAL 117 certified foam. Joints are glued, stapled and screwed to ensure frame stability and longevity. Walnut premium laminate base is thoroughly protected from heat, moisture and scratches.





SKU: LEON-Z-BOWLING-PACKAGE



PRODUCT SPECIFICATIONS

The Leon Sofa brings a touch of modern elegance and comfort to any commercial setting. Its signature slanted arms create a graceful “wave” from the top of the back panel to the bottom, offering full arm support for guests. Crafted in the USA with sturdy 4 inch metal legs, this sofa supports up to 350 lbs, making it ideal for hospitality lounges, public spaces, and stylish gathering areas. The Leon Sofa’s clean lines, plush upholstery, and versatile color options make it a stunning choice for any environment that prioritizes both comfort and style.

Frame is built of solid hardwood. Cushion is made of high density CAL 117 certified foam. Joints are glued, stapled and screwed to ensure frame stability and longevity. The Twinbox lounge table is built on commercial-grade laminated platform. Top of the table has a divider to separate the parties along with a storage convenience on each side. Available in many finishes. Measures 48” x 28” x 16.

Leon Sofa: Length: 73” (3-Seater) | Depth: 27” | Height: 32” | Seating Depth: 20” | Seating Height: 17”
 Norway Booth: Length: 48” (2-Seater) | Depth: 24.5” | Height: 36” | Seating Depth: 19” | Seating Height: 18”
 Restarant table: Length 48” | Width 30” | Height 30”





SKU: GOLF-PACKAGE



PRODUCT SPECIFICATIONS

The Golf Simulator Furniture Package is the most popular and efficient seating solution designed specifically for today's high-performance simulator facilities. This complete package includes a sectional sofa, lounge tables, communal table, and bar stools, creating the perfect balance between player seating, guest viewing, dining, and social interaction within a compact footprint.

Designed with space optimization in mind, this package is ideal for golf simulator rooms where every inch matters. Whether installed in individual simulator stalls, private cabins, or open multi-bay facilities, the layout allows operators to maximize seating capacity without sacrificing comfort or circulation. Players stay focused, while guests remain comfortable and engaged throughout the experience.

Built for commercial durability and daily use, each component is engineered to withstand high traffic, food service, and extended hours of operation. The versatile layout works equally well for entertainment venues, training centers, sports bars, hospitality suites, and private clubs, making this package a proven, revenue-driven solution for any simulator environment.

- Lugano-Z Chair: Length 36" | Depth 27" | Height 28"
- Lugano-Z Extension: Length 72" | Depth 27" | Height 28"
- Communal Table: Length 72" | Width 36" | Height 36"
- Bar Stool: 18" Round | Height 30"
- Lounge Table: Length 24" and 42" | Width 24" | Height: 16"

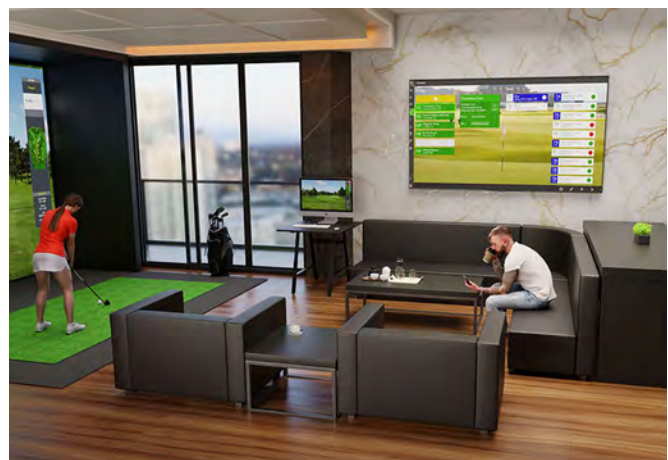



SKU: GOLF-PACKAGE-CAPRI



PRODUCT SPECIFICATIONS

The Modern Golf Furniture Package is designed for today's golf simulator facilities, country clubs, and sports lounges. This complete set includes the Capri 3-seater sofa for group seating, plus two swing tray task chairs with built-in USB/110V outlets for personal comfort. A set of cube lounge tables provides space for food and drinks, while bar tables and stools create an elevated view of the action. Made in the USA with durable construction, this package delivers flexibility, comfort, and a stylish setup that can be easily reconfigured to fit any group size.

Capri Sofa: Length 73" (3-Seater) | Depth: 27" | Height: 31" | Seating Depth 21" | Seating Height 16.5"

Capri Chair: Length 27" | Depth: 27" | Height: 31" | Seating Depth 21" | Seating Height 16.5"

Bar Table: Length 42" | Width 24" | Height 42"

Bar Stool: Width 18" | Depth 18" | Height 41" | Seat Height 31"

Cube Lounge Table: Square 24" | Height 18"





SKU: GOLF-MAPLE-BOOTHS



PRODUCT SPECIFICATIONS

These booths delivers durability, comfort, and style all in one sleek package. Featuring dual black button-tufted panels, this model restaurant booth adds timeless sophistication to any restaurant setting. Built with a solid plywood frame and fully reinforced with bolts and screws, each seat is designed to support up to 400 lbs — making it ideal for high-traffic hospitality venues. The clean lines and sharp contrast between the tufted upholstery and maple frame bring a polished, upscale look to dining spaces. For added functionality, you can include built-in charging stations — perfect for today’s tech-connected guests. Whether you’re designing a casual café or an upscale lounge, this USA-made booth offers unmatched quality and versatility.

Maple Booth: Length 48” | Depth: 23” | Height: 48” | Seating Depth 19” | Seating Height 18.5”
 Communal Bar Table: Length 96” | Width 24” | Height 42”
 Bar Stool: Width 16” | Depth 16” | Height 31”





SKU: TIFFANY PACKAGE



PRODUCT SPECIFICATIONS

The TIFFANY is a modern commercial restaurant booth with a channel design which offers an elegant and functional seating option designed to enhance the dining experience. The booth features a sleek, contemporary design characterized by its clean lines and sophisticated appearance. Ideal for modern dining establishments, these booths can be customized in various colors, sizes, and finishes to complement the restaurant's décor and layout. They provide a cozy and intimate dining space for guests, making them a popular choice for both casual and upscale dining venues.

Unique channel-tufted luxury booth designed to be trendy and comfortable. Comfortable seat cushion is made from high-quality CAL 117 high density foam. Solid wood frame and commercial-grade materials provide durability and resilience in high traffic areas. 4" tall dark metal legs. Glossy Glaze Collection: Features beautiful, smooth and semi-glossy leather grain pattern. Excellent performance commercial grade-vinyl with 100,000 double rubs. Phthalate free and Lead free. It is California TB 117 fire code certified.

Felicity Booth: Length 72" | Depth: 27" | Height: 36" | Seating Depth 21" | Seating Height 18"
 Restaurant Table: Length 48" | Width 30" | Height 30" | Table Top Thickness: 1/2"
 Restaurant Chair: Width 22" | Depth 22" | Height 36" | Seating Height: 18.5"





SKU: 85 PACKAGE



PRODUCT SPECIFICATIONS

When you want to make a bold statement in a public lounge, hospitality venue, or event space, nothing compares to the sculptural beauty and comfort of Model 85. This large modular seating layout uses a combination of curved extensions, left- and right-sided chaises, and open-back modules to create a flowing, architectural centerpiece that invites people in. With deep seating, supportive backs, and optional round ottomans and Lucas tables for added functionality, this configuration is perfect for VIP lounges, hotel lobbies, or banquet spaces. Each modular component connects easily, giving you complete flexibility to adapt the shape and direction to fit your floor plan. Whether you need a closed semi-circle booth seating, a free-flowing arc, or multiple zones of comfort, the 8005 Modular Seating Collection delivers style, luxury, and crowd-pleasing comfort — all with the signature curves that elevate every room it enters.

Left-Sided Chaise: Length 77" | Width 34" | Height 31" | Seating Depth 26" | Seating Height 17"

Right-Sided Chaise: Length 77" | Width 34" | Height 31" | Seating Depth 26" | Seating Height 17"

Overall Length: 143"

Lucas Loung Table: Round 30" | Height 18"





SKU: CHARLESTON-BOOTHS-PACKAGE



PRODUCT SPECIFICATIONS

This upscale and sophisticated collection of CHARLESTON Single and Double Restaurant booths offers wide seating space and flexibility in dining experience for your restaurant guest. It's designed to meet commercial grade. The Tufted, Channel and Diamond Back panels can be connect-ed to wall divider which will provide privacy and space efficiency in your establishment. Your guest will appreciate the look and unique style of these Modular Restaurant Booths cubicles and will be coming back again.

Booth: Length 48" | Width 22" (Single), 41" (Double) | Booth Height 42" | Side Wall Height: 54" | Seating Depth 19" | Seating Height 18"
 Restaurant Table: Length 48" | Width 30" | Height 30"

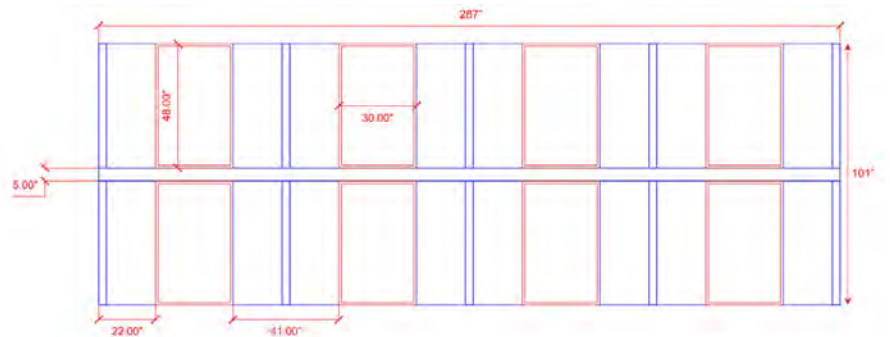



SKU: MOON PACKAGE



PRODUCT SPECIFICATIONS

The Diamond Tufted Half-Circle Booth brings old-world charm to modern spaces. Featuring hand-set button tufting in a diamond pattern, this model turns any seating area into a focal point — combining vintage appeal with commercial-grade durability.

Loved by steakhouses, fine dining restaurants, and VIP lounges, its rounded design gives guests a private, immersive experience while enhancing the room’s elegance. Built with a hardwood frame and tailored in your choice of fabric or vinyl. Elegance in every curve — and craftsmanship in every stitch.

Enhance your restaurant’s ambiance with our Booth Half-Circle Radius, a stylish seating option that combines comfort with elegance. Perfect for creating a cozy and intimate dining experience, the half-circle radius design offers a unique and inviting atmosphere for your guests.

Crafted with attention to detail, our Booth Half-Circle Radius features a curved seating area that promotes a comfortable and engaging dining experience. Space Optimization: Ideal for optimizing your restaurant’s space, this booth design maximizes seating capacity while maintaining a spacious and open feel.

Customizable: Available in various sizes, upholstery options and finishes to complement your restaurant’s decor and ambiance.

42” by 84” by 42” can accommodate table top up to 36” Round
 48” by 96” by 48” can accommodate table top up to 48” Round

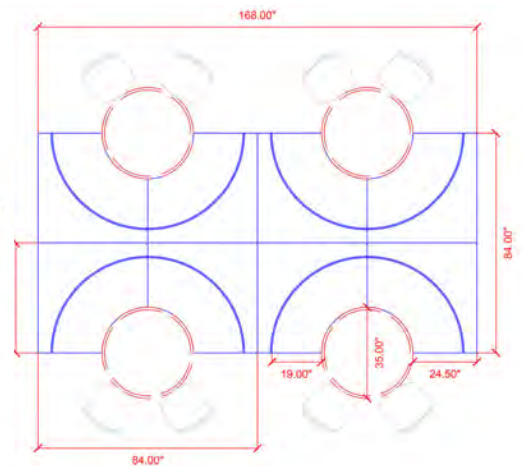



SKU: RELAX-PACKAGE



PRODUCT SPECIFICATIONS

The RELAX Lounge Seating Package brings the legendary Chesterfield style, a design admired for centuries, into a bold modern era with luxurious diamond-glaze vinyl and deep button tufting. This glamorous finish reflects light beautifully, creating a rich, upscale presence that instantly communicates comfort, prestige, and indulgence. It delivers a clear invitation: sit back, enjoy a cigar, and savor the moment.

Perfect for cigar lounges, upscale hotel bars, private clubs, whiskey lounges, and luxury hospitality spaces, the Escape collection blends timeless elegance with modern durability. The plush seating offers exceptional comfort for extended lounging, while the refined detailing makes it a true visual centerpiece.

The package is completed with round walnut accent tables, adding both warmth and function. These tables provide the ideal surface for drinks, cigars, and personal items, enhancing both convenience and atmosphere. The Escape collection is a symbol of confidence, luxury, and timeless craftsmanship.

Escape Sofa: Length 57" | Depth: 29" | Height: 31" | Seating Depth 20.5" | Seating Height 17.5"
 Escape Chair: Length 41" | Depth: 29" | Height: 31" | Seating Depth 20.5" | Seating Height 17.5"
 Restaurant Table: 30" Round | Height 30"

